

NUFLO™

Turbine Flowmeter Repair Kits

Installation Guide

NuFlo Flowmeter Repair Kits—3/8 in. to 3 in.

INSTRUCTIONS

Preparing for Installation

1. Remove the magnetic pickup or protect it to prevent damage.
2. Remove the K-factor tag from the meter, if present.
3. Remove the retainer rings from each end of the housing.*
4. Remove the upstream and downstream vanes and rotor. If the vanes are stuck, drive them out with a small wooden or plastic rod and hammer. Tap alternately on the blades of the vane to prevent damaging the housing.
5. Clean the bore of the housing with a swab and remove any burrs or rough spots.
6. Clean the retainer ring grooves to insure proper seating of the new rings.*

Installing Replacement Kit

1. Insert the downstream vane so the arrow on the vane corresponds with the direction of the arrow on the outside of the housing and the flow arrow on the vane blade is between the retainer pins or in the bottom broached groove.
2. Install the downstream retainer ring.*
3. Insert the rotor with the direction arrow properly aligned. Be sure its shaft enters the downstream bearing.
4. Place the upstream vane in the housing with the flow arrow on the vane blade between the retainer pins or in the bottom broached groove. If necessary, spin the rotor to permit its shaft to enter the bearing. **DO NOT FORCE THE VANE DOWN AGAINST THE ROTOR as this may break the rotor shaft.**
5. Install the upstream retainer ring.*
6. Be sure the rotor is free to spin before placing the meter in the flow line.
7. Attach the K-factor tag supplied with the kit. Wrap the strap of the tag around the conduit adapter, thread the end through the hole in the tag and pull tight. Cut off excess strap length.

*On 3/8-in., 1/2-in., and 3/4 in. flanged meters, the retainer ring is replaced with a threaded insert.

Meter Kit Size (in.)	Standard Grade	Industrial Grade
3/8	9A-100003521	9A-100003378
1/2	9A-100003531	9A-100003379
3/4	9A-100003449	9A-100003380
7/8	9A-100005124	9A-100061059
1	9A-100003527	9A-100003381
1 1/2	9A-100003469	9A-100003382
2	9A-100003474	9A-100003383
3	9A-100003470	9A-100061056

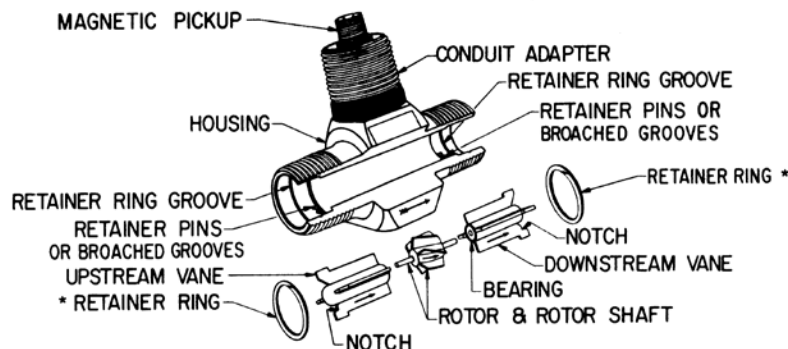

NuFlo Flowmeter Repair Kits—4 in. to 8 in.

INSTRUCTIONS

Preparing for Installation

1. Remove the magnetic pickup or protect it to prevent damage.
2. Remove the K-factor tag from the meter, if present.
3. Remove the outer retainer rings from each end of the housing.
4. Remove the upstream and downstream vanes and rotor. If the vanes are stuck, drive them out with a small wooden or plastic rod and hammer. Tap alternately on the blades of the vane to prevent damaging the housing.
5. Remove the inner retainer rings and rotor.
6. Clean the bore of the housing with a swab and remove any burrs or rough spots.
7. Clean the retainer ring grooves to insure proper seating of the new rings.

Installing Replacement Kit

1. Insert the downstream inner retainer ring.
2. Insert the downstream vane so the arrow on the vane corresponds with the direction of the arrow on the outside of the housing and the flow arrow on the vane blade is between the retainer weld spots.
3. Install the downstream outer retainer ring.
4. Insert the rotor with the direction arrow properly aligned. Be sure its shaft enters the downstream bearing.
5. Install the upstream inner retainer ring.
6. Place the upstream vane in the housing with the flow arrow on the vane blade between the retainer weld spots. If necessary, spin the rotor to permit its shaft to enter the bearing. **DO NOT FORCE THE VANE DOWN AGAINST THE ROTOR as this may break the rotor shaft.**
7. Install the upstream outer retainer ring.
8. Be sure the rotor is free to spin before placing meter in flow line.
9. Attach the K-factor tag supplied with the kit. Wrap the strap of the tag around the conduit adapter, thread the end through the hole in the tag and pull tight. Cut off excess strap length.

Meter Kit Size (in.)	Standard Grade	Industrial Grade
4	9A-100003473	9A-100003384
6	9A-100003471	9A-100061057
8	9A-100003472	9A-100061058

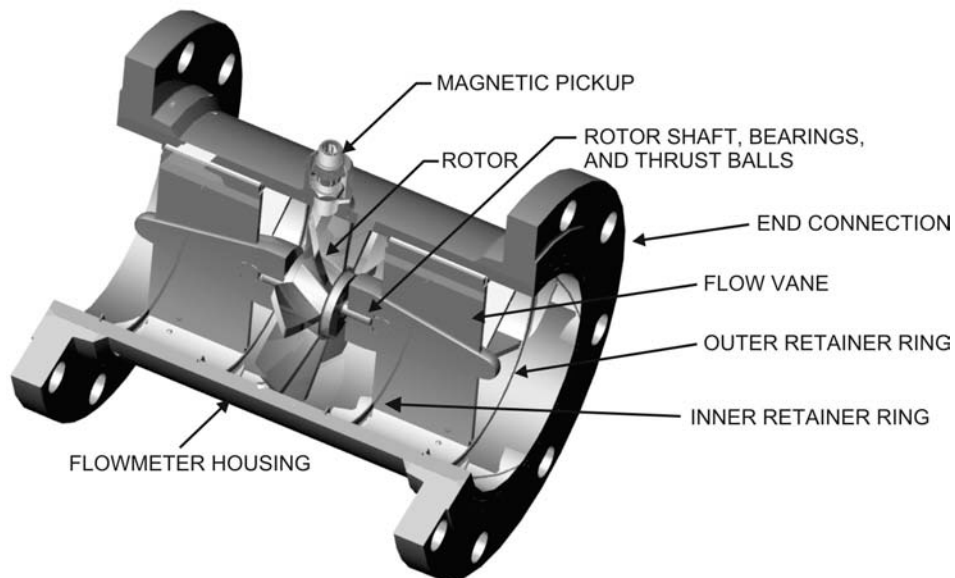

NuFlo EZ-IN Flowmeter Repair Kits—All Sizes

INSTRUCTIONS

Preparing for Installation

1. Remove the magnetic pickup or protect it to prevent damage.
2. Remove the K-factor tag from the meter, if present.
3. Remove the three socket head capscrews from each end of the housing.
4. Remove the upstream and downstream bearing supports and rotor. If the bearing supports are stuck, drive them out with a small wooden or plastic rod and hammer. **Use extreme caution in prying on the bearing supports to prevent the internal parts from breaking or shattering.** Tap alternately on the blades of the supports to prevent damaging housing.
5. Clean the bore of the housing with a swab and remove any burrs or rough spots.
6. Clean the screw hole area to insure proper seating of the new capscrews.

Installing Replacement Kit

1. For ease in removal, grease the outside of the bearing supports and the socket head capscrews.
2. Insert the downstream bearing support so the direction of the flow arrow corresponds with the arrow on the outside of the housing. Align the index marks (punch marks) on the bearing support and the edge of the housing.
3. Install the downstream retaining capscrews and tighten.
4. Insert the rotor with the direction arrow properly aligned. Be sure its shaft enters the downstream bearing.
5. Insert the upstream bearing support in the housing and align the index marks. If necessary, spin the rotor to permit its shaft to enter the bearing. **DO NOT FORCE THE BEARING SUPPORT DOWN AGAINST THE ROTOR as this may break the rotor shaft.**
6. Install the upstream retaining capscrews and tighten.
7. Be sure the rotor is free to spin before placing the meter in the flow line.
8. Attach the K-factor tag supplied with the kit. Wrap the strap of the tag around the conduit adapter, thread the end through the hole in the tag and pull tight. Cut off excess strap length.
9. Screw the magnetic pickup in all the way and then unscrew 1/4 turn. Lock the pickup retainer nut.

Meter Kit Size (in.)	Standard Grade	Industrial Grade
3/8 x 2	9A-100079691	9A-101209535
1/2 x 2	9A-100005122	9A-100062982
3/4 x 2	9A-100079674	9A-100062983
7/8 x 2	9A-100079811	9A-101209539
1 x 2	9A-100005123	9A-100062984
1 1/2 x 2	9A-100005099	9A-100062985
2	9A-100003553	9A-100003549
3	9A-100003540	9A-100012104
4	9A-100003554	9A-100062986
6	9A-100012091	9A-100062987
8	9A-100063004	9A-100062988

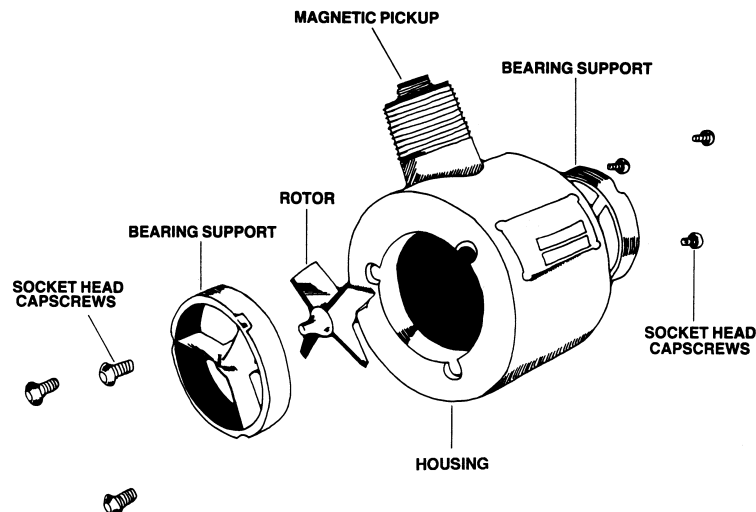

Flowmeter Calibration

This kit has been calibrated with water over the recommended operating range. A calibration tag designating pulses per gallon observed during factory calibration is included with this kit.

© 2010 Cameron International Corporation (“Cameron”). All information contained in this publication is confidential and proprietary property of Cameron. Any reproduction or use of these instructions, drawings, or photographs without the express written permission of an officer of Cameron is forbidden.

All Rights Reserved.
Printed in the United States of America.

Manual No. 9A-100061169, Rev. 01
September 2010

WARRANTY - LIMITATION OF LIABILITY: Seller warrants only title to the products, software, supplies and materials and that, except as to software, the same are free from defects in workmanship and materials for a period of one (1) year from the date of delivery. Seller does not warranty that software is free from error or that software will run in an uninterrupted fashion. Seller provides all software "as is". THERE ARE NO WARRANTIES, EXPRESS OR IMPLIED, OF MERCHANTABILITY, FITNESS OR OTHERWISE WHICH EXTEND BEYOND THOSE STATED IN THE IMMEDIATELY PRECEDING SENTENCE. Seller's liability and Buyer's exclusive remedy in any case of action (whether in contract, tort, breach of warranty or otherwise) arising out of the sale or use of any products, software, supplies, or materials is expressly limited to the replacement of such products, software, supplies, or materials on their return to Seller or, at Seller's option, to the allowance to the customer of credit for the cost of such items. In no event shall Seller be liable for special, incidental, indirect, punitive or consequential damages. Seller does not warrant in any way products, software, supplies and materials not manufactured by Seller, and such will be sold only with the warranties that are given by the manufacturer thereof. Seller will pass only through to its purchaser of such items the warranty granted to it by the manufacturer.

MEASUREMENT SYSTEMS

HOUSTON HEAD OFFICE	281.582.9500	NORTH AMERICA	1.800.654.3760 ms-us@c-a-m.com	ASIA PACIFIC	+603.5569.0501 ms-kl@c-a-m.com	EUROPE, MIDDLE EAST & AFRICA	+44.1243.826741 ms-uk@c-a-m.com
------------------------	---------------------	------------------	--	-----------------	--	------------------------------------	---

USA • CANADA • UK • SCOTLAND • CHINA • UAE • ALGERIA • MALAYSIA • INDIA • KENYA • www.c-a-m.com/flo

