

OPERATING, INSTALLATION & MAINTENANCE MANUAL

Jiskoot™ Series 210 Hybrid Cell Sampler

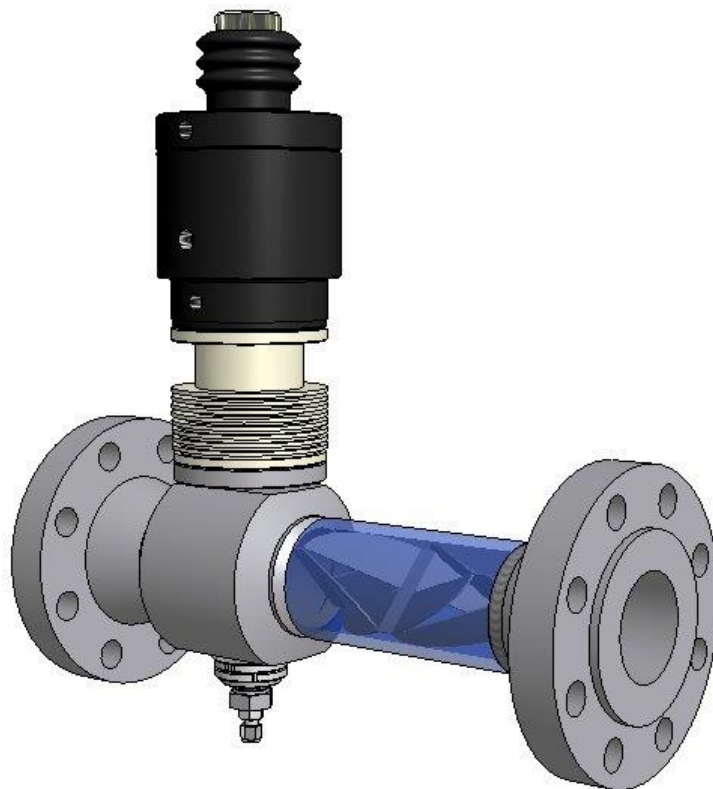

IMPORTANT SAFETY INFORMATION

Symbols and Terms used in this manual:



This symbol identifies information about practices or circumstances that can lead to personal injury or death, property damage, or economic loss.



This symbol indicates actions or procedures which if not performed correctly may lead to personal injury or incorrect function of the instrument or connected equipment.

Note

Indicates actions or procedures which may affect instrument operation or may lead to an instrument response which is not planned.

Regular Inspection **AT LEAST ANNUALLY** of any installation for corrosion is mandatory to safety. This assembly uses bolts under tension when inserted into a pipeline. Corrosion of these bolts can lead to failure, leakage, ejection and life-threatening personal injury and significant environmental and infrastructure damage.

Any replacement parts should be provided by the Sensia and serviced by qualified staff suitably trained. Bolts must meet the original design specification for strength, dimensions and coating protection and installed in accordance with this manual. In case of doubt, consult the factory.

Sensia, a joint venture between industry leading companies Schlumberger and Rockwell Automation, brings together the best of the best. The pioneering process automation, real-time control and IoT technologies of Rockwell Automation, combined with the unmatched measurement and instrumentation, analysis, software and analytics capabilities of Schlumberger. It is further strengthened by the oil and gas domain expertise and artificial lift experience shared by both parent companies and will be comprised of over 1,000 experts from both Rockwell Automation and Schlumberger, based in 40 countries serving our customers worldwide.

JISKOOT, one of Sensia's market-leading measurement systems brands, is a specialist provider of high accuracy measurement solutions for sampling and blending. The JISKOOT™ brand specializes in the project management, design, manufacture, commissioning and servicing of instrumentation and systems for control, sampling, blending and measurement. A specialist team of design, project and site engineers have the expertise to provide fully integrated solutions from a simple product to a complete packaged solution.

Technical Support Contact Information:

Sensia UK Limited
Jiskoot Technology Centre
Longfield Road
Tunbridge Wells
Kent, TN2 3EY,
United Kingdom

Email: Measurement@sensiaglobal.com

Jiskoot™ is a trademark of Sensia UK Limited

Copyright © 2019 Sensia UK Limited. All information contained in this publication is confidential and proprietary property of Sensia. Any reproduction or use of these instructions, drawings, or photographs without the express written permission of an officer of Sensia is forbidden.

All Rights Reserved. Printed in the United Kingdom.

04	Sections 6 and 8 re-written in line with 2019 build incorporating all design upgrades and variations.	R. Best	S. Papworth	Jan 2020
3	Amend Testing Section 9 (This Revision Not Issued)	N.McGee		Apr 2014
2	Fig 5 (Support Tube sealing) Add sample adjustment and setup Extend illustration	N.McGee	J. Baker	Dec 2012
1	First Issue	N.McGee	J. Baker	Jan 2012
Issue	Description of Change	Issued	Approved	Date

TABLE OF CONTENTS

1	Introduction	1
2	Operating Instructions	3
3	Glossary of Special Terms	3
4	Utilities Reference	3
5	Functional Description	4
6	Drawings & Bill of Materials	5
7	Installation Details	12
8	Maintenance and Troubleshooting	14
	8.1 Health and Safety Precautions	14
	8.2 Weekly maintenance	14
	8.3 Annual maintenance (or as determined by site conditions).....	14
	8.4 Overhaul Instructions.....	15
	8.5 Torque Settings.....	15
	8.6 Overhaul	16
	8.7 Re-Assembly.....	23
9	Testing	33
	9.1 Witness testing prior to re-installing the Sampler in service.....	33
	9.2 Test equipment	33
10	Frequently Asked Questions	35
	10.1 Sampler Does Not Operate	35
	10.2 Sampler Operates but Does Not Produce A Sample	35
	10.3 Sampler fails to take adequate sample	35
	10.4 Sampler takes excessive sample	36
	10.5 Process Fluid Leaks.....	36
	10.6 Vibration.....	36
11	Recommended Spares List	36
	11.1 Special Tool Kits	36
	11.2 Ancillary Equipment	36
12	Product Specific Drawings	36
13	Addenda	37
	13.1 2cc Cell Sampler.....	37
	13.2 Addenda – Grab Volume Adjustment	37
14	Disclaimer	39

Figure 1 – Hybrid Cell Samplers 4” High Pressure and 2” High Temperature with Static Mixer	1
Figure 2 - Jiskoot™ Series 210 Cell Sampler 3 step operation	4
Figure 3 - 210 Sampler Actuator	5
Figure 4 - 210 Sampler Hydraulic Actuator components	6
Figure 5 - 210 Sampler High Pressure Actuator	7
Figure 6 - 210 Hybrid Cell Sampler Support Tube	8
Figure 7 – 210 Hybrid Cell Sampler Bottom Plug	9
Figure 8 – 210 Sampler High Temperature Spacer	10
Figure 9 – 210 Hybrid Cell Sampler Capture and Sample Tubes	11
Figure 10 - 210 Sampler Typical Installation	12
Figure 11 - Test Configuration	34

1 Introduction

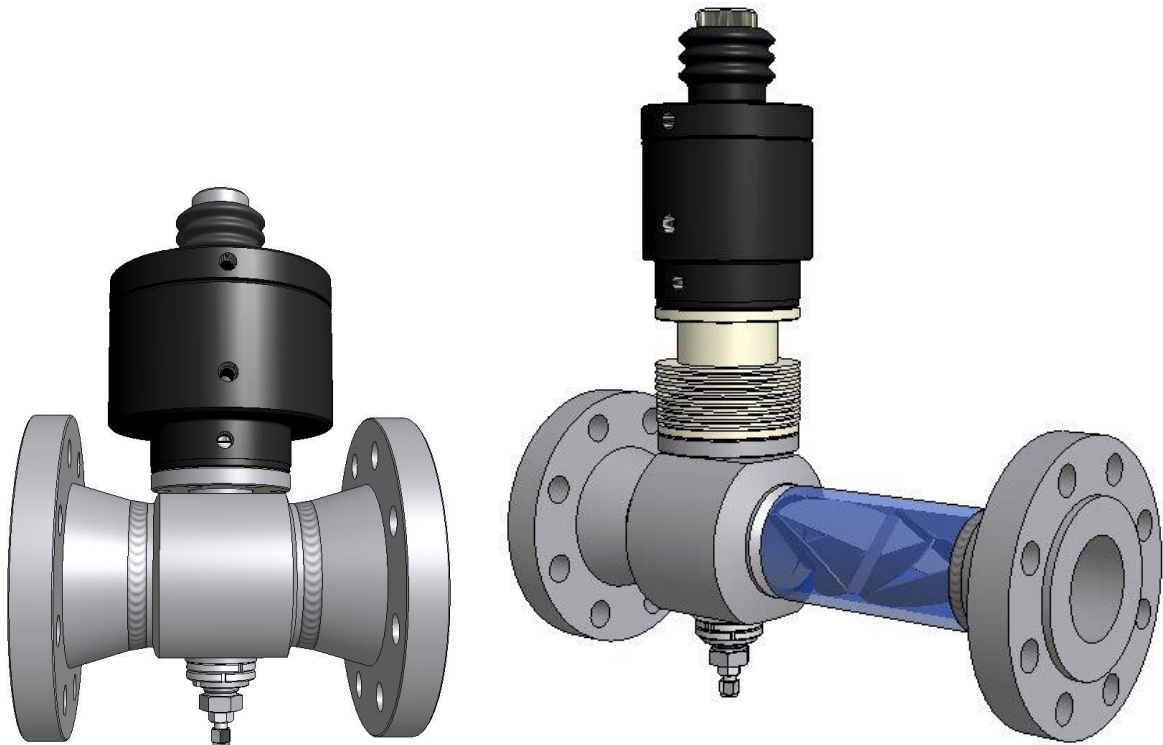

Figure 1 – Hybrid Cell Samplers 4" High Pressure and 2" High Temperature with Static Mixer

Truly representative sampling of crude oils and other hydrocarbons cannot be achieved by a single product in isolation. A well-designed system and operating procedures as laid down in the Sampling Standards ISO 3171, API 8.2, and IP 476 are mandatory.

As part of a well-designed sampling system, the Jiskoot™ Series 210 Hybrid Cell Sampler extracts a sample from liquids flowing in pressurised bypass loops or small pipelines. Primarily designed for applications where air pressure provides the motive power, the Hybrid Cell Sampler is installed directly within a 2-inch, 3-inch or 4-inch main pipeline or bypass loop.

The Jiskoot™ Series 210 Hybrid Cell Sampler incorporates an expanded body for the sample extraction process ensuring the Hybrid Cell Sampler adds negligible pressure drop to an existing process piping system.

The Jiskoot™ Series 210 Hybrid Cell Sampler is designed to extract nominal 1 cc or 2 cc samples from products ranging from crude oil, refined hydrocarbons (including non-lubricating products) and non-corrosive chemicals. Operating in a pressure range from 3 to 99 barg, within a product design temperature range of -20 degC to 200 degC, on viscosities 0.5 to 5000 cSt in an ambient temperature range of -20 degC to 40 degC.

The Jiskoot™ Series 210 Hybrid Cell Sampler is available as full bore 2-inch, 3-inch or 4-inch flanged 150#, 300# or 600# raised face and 600# RTJ, with or without Static Mixer. Pneumatically actuated as standard with an option for hydraulic actuation for use with a hydraulic power pack for installations with no air supply.

The performance and seal life of the Jiskoot™ Series 210 Hybrid Cell Sampler is dependent upon site process pressure, viscosity, sampled product and outlet configuration, including tubing, valves and pressurised sample receivers. Consult Jiskoot™ for sample receiver options.

This Jiskoot™ Series 210 Hybrid Cell Sampler is designed to provide outstanding service if correctly installed, used and maintained recognising the effects of the process conditions (temperature, pressure, wax/pour point, sediment, etc.).

Note

When requesting assistance or spare parts, please provide the Cell Sampler Material No. and Serial Number to ensure that the correct options are quoted.

The disassembly / reassembly instructions described herein are for the 210 Hybrid Cell Sampler standard configuration, except where otherwise noted. Primary differences between pneumatic, electro-hydraulic, and high-pressure samplers are found in the actuator assembly refer to the Drawings Section.

2 Operating Instructions

The Jiskoot™ Hybrid Cell Sampler must be installed in accordance with the Installation Details, and be connected to a suitable sample collection system, via an external line balanced or back pressure check valve.

The Pneumatic Sampler requires a regulated air supply of between 4 and 8 barg (60 to 115 psig) and an energising signal to function the external Sampler Solenoid valve, actuating the sampler. The Hydraulic Sampler requires a hydraulic power pack to provide the pressure source of between 5 and 10 barg (75 to 145 psig).

Any pipeline conditioning facility must be active to ensure a representative product is available to the Sampler.

Control of the Sample outlet, including changeover of Sample Receivers will be determined by the type of Sampler Control System being used.

3 Glossary of Special Terms

Grab The action of taking an individual sample (normally 1 or 2 ml) from the pipeline.

4 Utilities Reference

Air Supply – (Pneumatic samplers only)		4 - 8 barg (60 - 115 psig)
Air Consumption	Standard Actuator	0.8 m ³ /hr or 0.47 scfm (5 barg at 30 grabs/min)
	High Pressure Actuator	1.67 m ³ /hr or 1.0 scfm (5 barg at 30 grabs/min)
Solenoid Voltages Available	AC	100 to 254 Volts 50 / 60 Hz
	DC	24 Volts DC
	Power Consumption	10 Watts
Solenoid energisation time	500 milliseconds (dependent upon installation and actuation type)	
Maximum Sampling Rates	Standard Actuator Air Operation	120 grabs/min
	High Pressure Actuator Air Operation	60 grabs/min
	Standard Actuator Hydraulic Operation	50 grabs/min
	High Pressure Actuator Hydraulic Operation	30 grabs/min

5 Functional Description

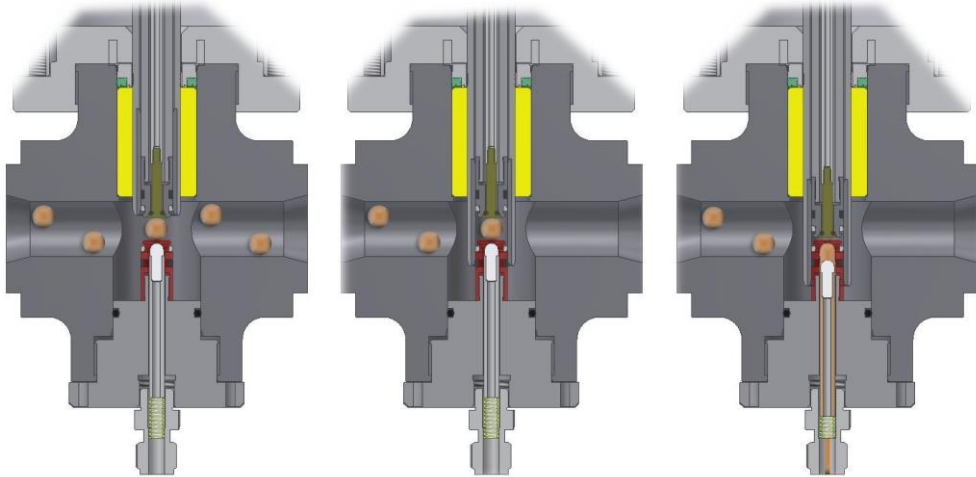

Figure 2 - Jiskoot™ Series 210 Cell Sampler 3 step operation

The Hybrid Cell Sampler operates on Jiskoot™'s standard 3-step principle, using an air or hydraulically actuated piston to provide the motive power.

In the idle (de-energised) state, air pressure is applied to the bottom of the Actuator Housing through Port B, holding the Capture Tube and the Sample Tube at the top of their stroke and allowing process product to flow through the Cell Sampler Body. Figure 2 (Left).

When the external sampler solenoid is energised, motive pressure is applied to Port A, forcing the piston down. Pressure from the underside of the piston is naturally exhausted through the valve to atmosphere. The downward movement of the combined piston and capture tube pass over the Lower Capture Tube Seal, trapping a nominal 1 cc or 2 cc of the product. Figure 2 (Centre).

In the third step, the continued downward motion collects and pulls the Catchplate, drawing the Sample Tube along with the Capture Tube downward. The trapped sample compresses the internal Check Valve and spring and ejects through the centre of the Bottom Plug, through the external back pressure check valve to the sample receptacle. Figure 2 (Right).

When the Sampler Solenoid is de-energised, motive pressure is exhausted from the top of the Actuator Housing and applied to the underside of the Piston, moving the Capture Tube and Sample Tube back to their start position. The spring returns the Check Valve with any vacuum being relieved via a Vacuum Breaker, incorporated within the Sample Tube.

Product continues to pass through the Cell Body and the Sampler is ready for the next grab to be initiated.

6 Drawings & Bill of Materials

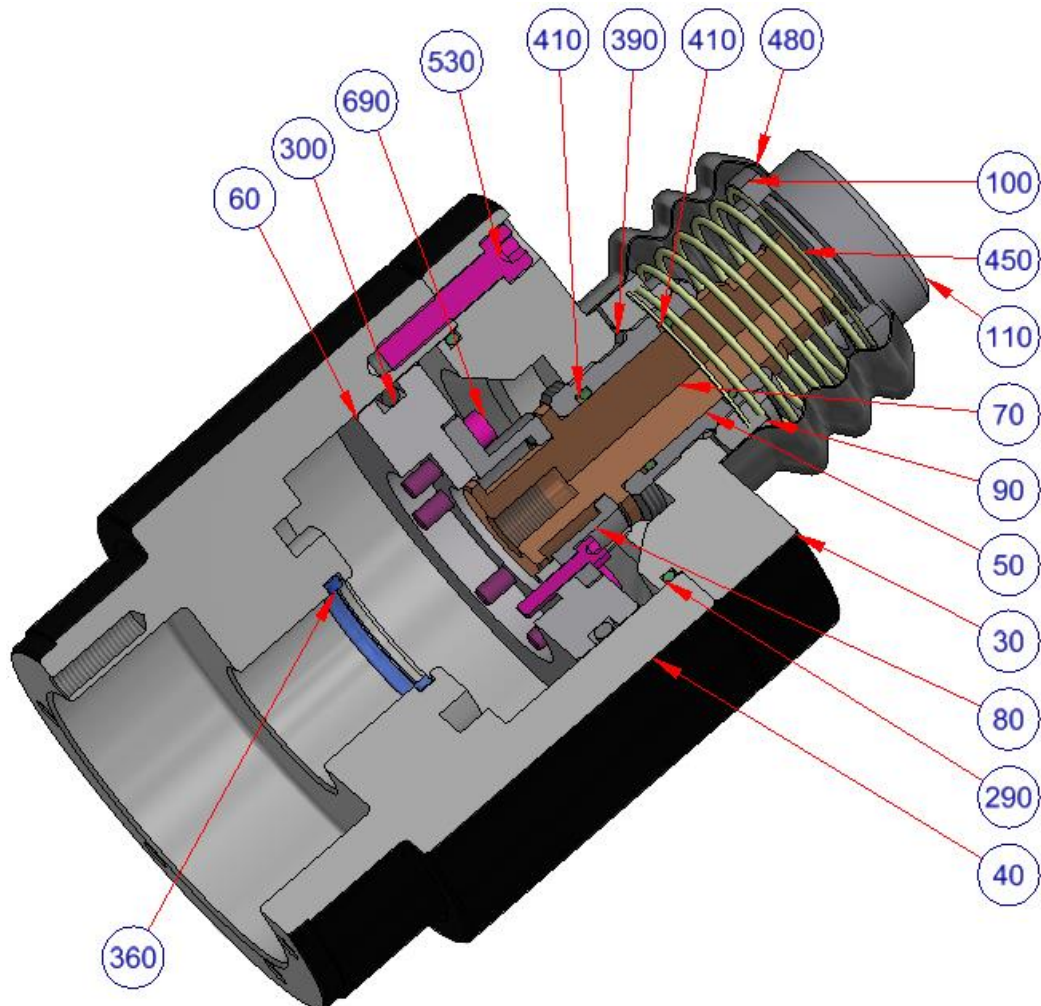

Figure 3 - 210 Sampler Actuator

Material List					
Item	Part No.	Description	Item	Part No.	Description
30	3J-36-1183-00	TOP HOUSING	290	3J-37-0015-00	O RING
40	3J-36-1184-00	HOUSING	300	3J-37-0033-00	O RING
50	3J-36-1185-00	SEALING BUSH	360	3J-37-0544-00	QUAD RING
60	3J-36-1186-00	PISTON	390	3J-37-0701-00	O RING
70	3J-36-5011-316	TUBE ACTUATOR	410	3J-37-0706-00	O RING
80	3J-36-1188-00	CATCHPLATE	450	3J-40-0082-00	SPRING
90	3J-36-1191-00	LOCK RING	480	3J-48-0465-00	GAITER
100	3J-36-1209-00	SPLIT COLLAR	530	3J-99-0030-00	SKT HD M8 x 35 mm
110	3J-36-1124-00	SAMPLE TUBE HEAD	690	3J-99-0027-00	SKT HD M5 x 20 mm

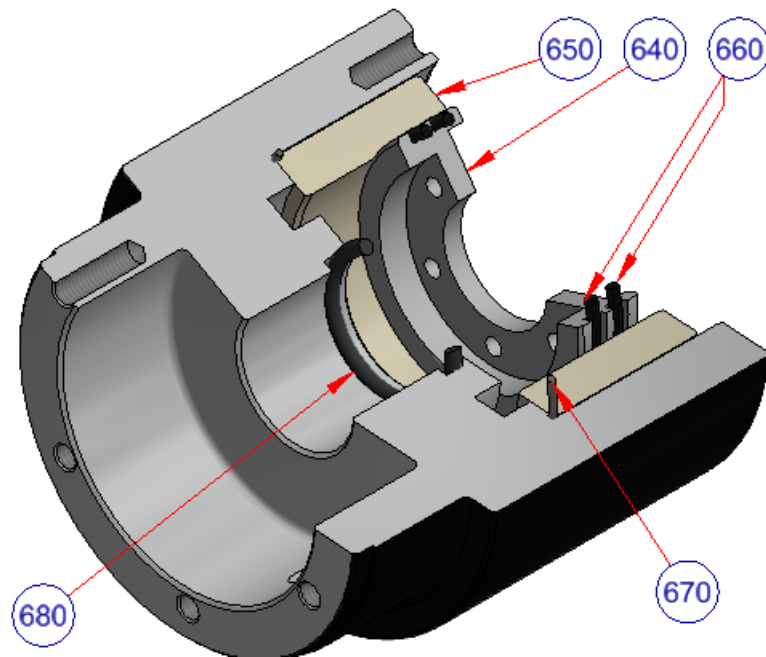

Figure 4 - 210 Sampler Hydraulic Actuator components

Material List					
Item	Part No.	Description	Item	Part No.	Description
640	3J-36-1215-00	EH PISTON	670	3J-37-0713-00	O RING
650	3J-36-1216-00	EH PISTON LINER	680	3J-37-0544-EH	O RING
660	3J-37-0704-00	O RING			

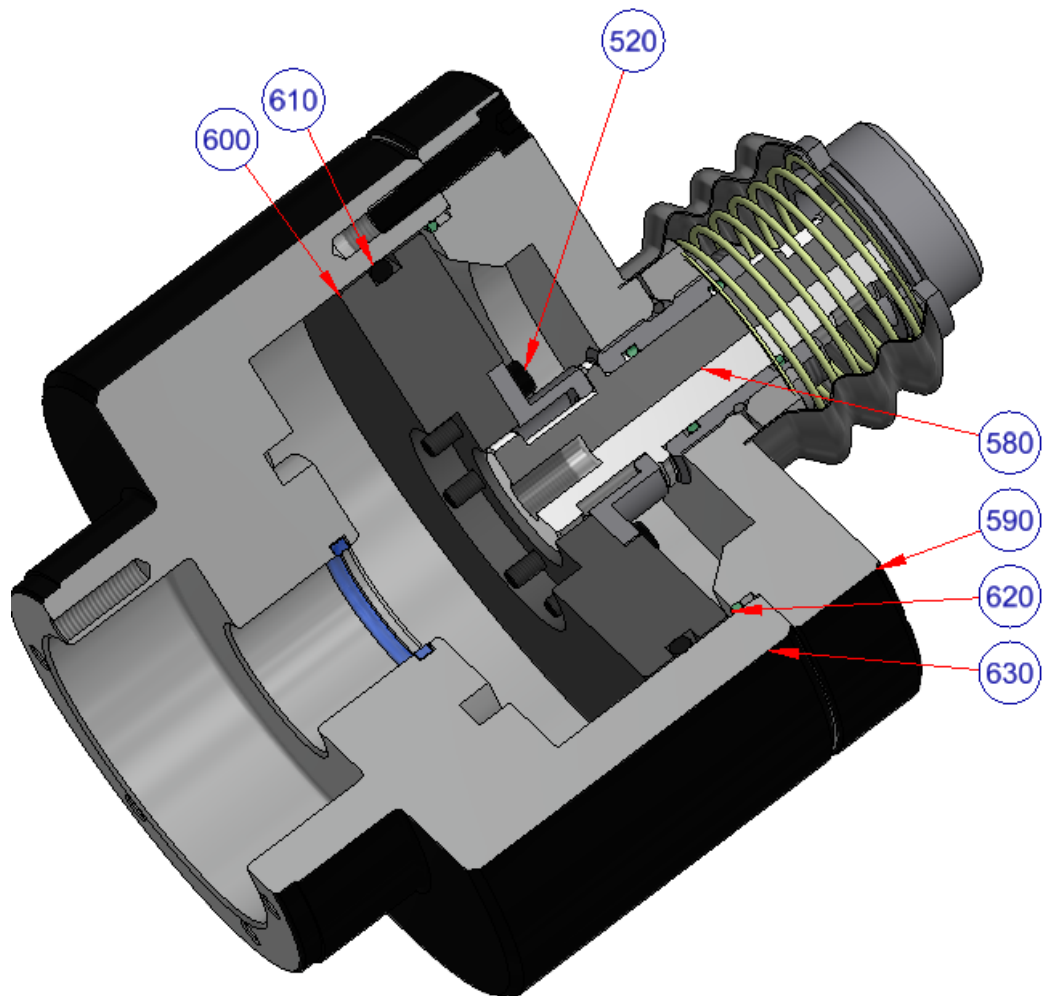

Figure 5 - 210 Sampler High Pressure Actuator

Material List					
Item	Part No.	Description	Item	Part No.	Description
520	3J-99-0015-00	SKT HD M5 x 25 mm	610	3J-37-0707-00	O RING
580	3J-36-5011-HT	HP TUBE ACTUATOR	620	3J-37-0708-00	O RING
590	3J-36-1297-00	HP TOP HOUSING	630	3J-36-1293-00	HP HOUSING
600	3J-36-1294-00	HP PISTON			

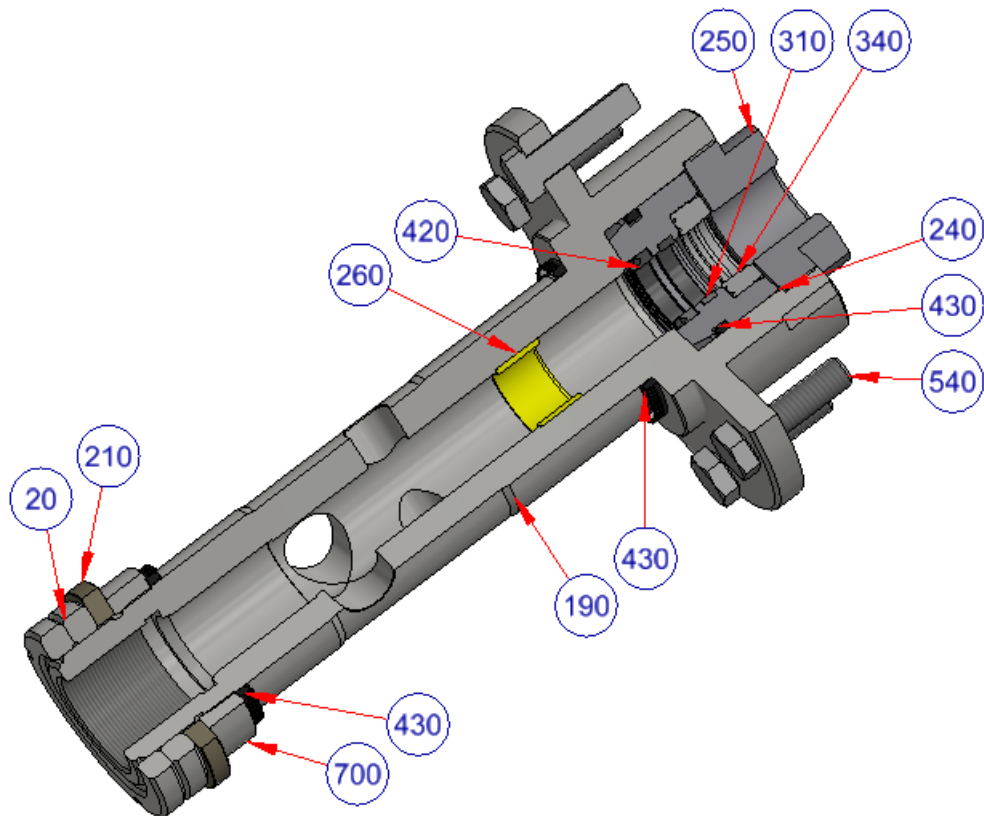

Figure 6 - 210 Hybrid Cell Sampler Support Tube

Material List					
Item	Part No.	Description	Item	Part No.	Description
20	3J-36-1134-00	LOCK RING	310	3J-37-0518-00	SLYDRING
190	3J-36-5032-00	HCS SUPPORT TUBE	340	3J-37-0531-00	SEAL GPTFE
210	3J-36-5034-00	BP TEMP SPACER	420	3J-37-0744-00	SEAL GPTFE
240	3J-36-5039-00	SEAL CARTRIDGE	430	3J-37-0827-00	SEAL GPTFE
250	3J-36-5040-00	LOCK RING	540		HEX HD M8 x 30 mm
260	3J-39-0418-00	WEAR BUSH	700	3J-36-4798-00	BP SPACER

Depending upon the flange size, multiples of Item 210 (3J-36-5034-00) BP TEMP SPACER and Item 700 (3J-36-4798-00) BP SPACER will be used. The arrangement must be maintained as supplied.

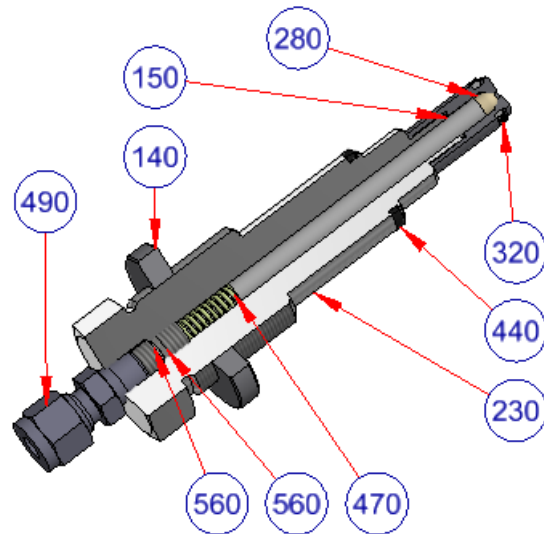

Figure 7 – 210 Hybrid Cell Sampler Bottom Plug

Material List					
Item	Part No.	Description	Item	Part No.	Description
140	3J-36-3106-00	STOP RING	470	3J-40-0084-00	SPRING
150	3J-36-3304-00	CHECK VALVE STEM	490	3J-49-0118-00	VCO CONNECTOR
280	3J-36-1229-00	CHECK VALVE	560	3J-99-0085-00	BORED SET SCREW
440	3J-37-0738-00	SEAL GPTFE			

HCS VARIANT	BOTTOM PLUG	BOTTOM PLUG SEAL
	Item 230	Item 320
Grab size 1 cc	3J-36-5038-01	3J-37-0519-00
Grab size 2 cc	3J-36-5038-02	3J-37-0540-00

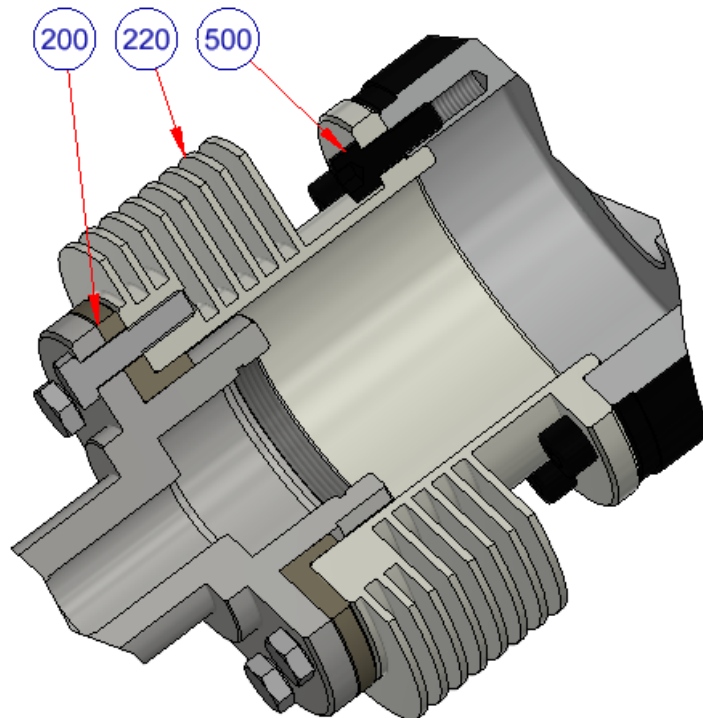

Figure 8 – 210 Sampler High Temperature Spacer

Material List					
Item	Part No.	Description	Item	Part No.	Description
200	3J-36-5033-00	HT SPACER	500	3J-99-0033-00	CAP HD M8 x 25 mm
220	3J-36-5035-00	TEMP SPACER			

NOTE. On Serial numbers 121402391001, 121402391002 and 121418130001, Item 500 uses Cap Head Screw M8 x 20 mm

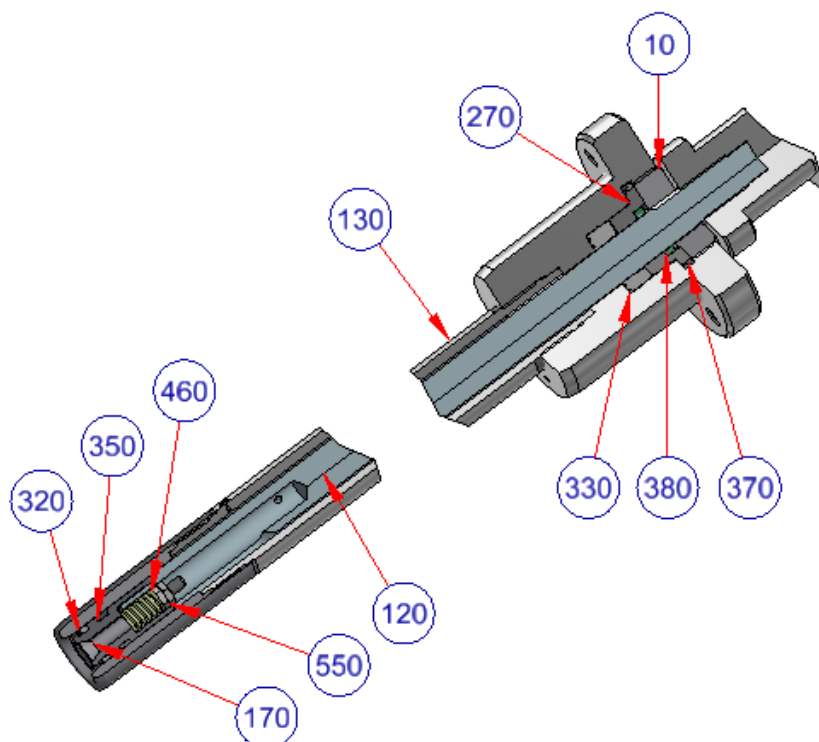

Figure 9 – 210 Hybrid Cell Sampler Capture and Sample Tubes

Material List					
Item	Part No.	Description	Item	Part No.	Description
10	3J-36-1102-00	SEAL NUT	370	3J-37-2550-00	O RING
170	3J-36-4480-S45	VACUUM VALVE	380	3J-37-0551-00	QUAD RING
270	3J-36-1190-00	SEAL RING	460	3J-40-0083-00	SPRING
330	3J-37-0530-00	SEAL GPTFE	550	3J-99-0013-00	HALF NUT M3
350	3J-37-0532-00	SLYDRING			

HCS VARIANT	CAPTURE TUBE & LPR	SAMPLE TUBE & VACUUM VALVE	SAMPLE TUBE SEAL	CAPTURE & SAMPLE TUBES Sub-Assembly
	Item 130	Item 120 + 170 + 460 + 550	Item 320	
Standard & High Pressure 1cc	3J-36-5101-01	3J-36-5103-01	3J-37-0519-00	3J-36-5105-01
High Temperature 1cc	3J-36-1344-LPR	3J-36-3614-01	3J-37-0519-00	3J-36-3612-01
Standard & High Pressure 2cc	3J-36-5101-02	3J-36-5103-02	3J-37-0540-00	3J-36-5105-02
High Temperature 2cc	3J-36-3463-LPR	3J-36-3614-02	3J-37-0540-00	3J-36-3612-02

7 Installation Details

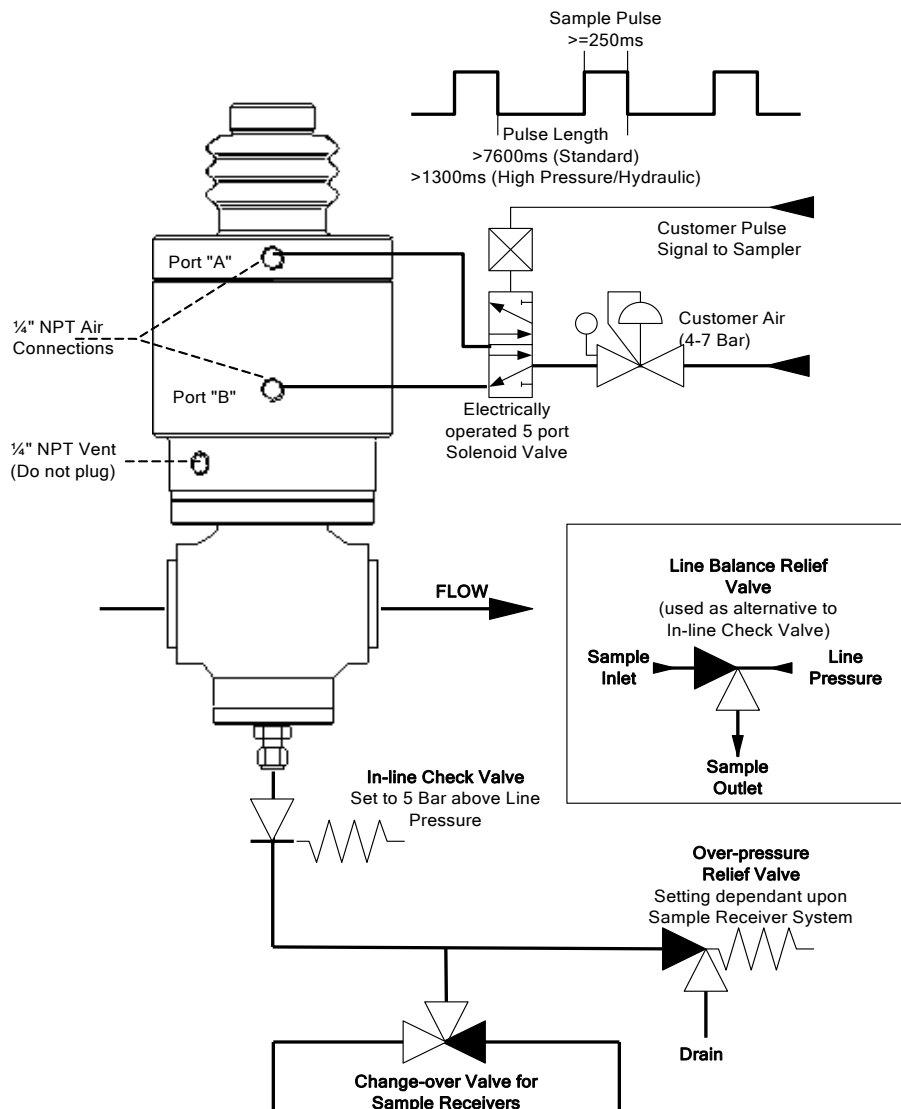

Figure 10 - 210 Sampler Typical Installation

The Jiskoot™ Series 210 Hybrid Cell Sampler is designed to be bolted between a pair of 2", 3" or 4" ANSI 150# RF, ANSI 300# RF or ANSI 600# RF (RTJ) flanges and can withstand static pressure testing to full flange rating.

It is crucial that the flow through the bypass loop and cell sampler is adequately mixed regarding the properties of interest. Where sampling for water content Sensia recommend that a minimum flow velocity within the cell sampler and for 1 metre upstream exceeds 3.5 m/s (6 m³/h).

The axis of the outlet tubing connection should be horizontal or downward facing to prevent water traps.



A Sampler Solenoid Valve must be selected to suit the specific application and will require connecting to suitable supplies via glands and cables appropriate to the area classification.



The correct rating fuse must be included in the Solenoid Valve supply circuit.

A regulated air supply must be connected to the Solenoid and the normally energised outlet connected to Port 'B' of the Sampler. The normally de-energised port of the Solenoid must be connected to Port 'A'. The exhaust port(s) of the Solenoid may be piped away or fitted with silencers as required. (On Electro-Hydraulic applications, the Solenoid is incorporated into the Hydraulic Power Pack)

If required, the bottom port (drain cavity) of the Actuator may be connected to a suitable drain or a pressure switch if used for leak detection.

The 1/4-inch Sample Outlet Port in the Bottom Plug must be connected to the Sample Receiver System using 1/4-inch stainless steel tubing via either a Jiskoot™ in-line Check Valve or a Jiskoot™ Line Balanced Relief Valve together with a relief valve as shown in the above diagram. For 6mm tubing an external tube adaptor would be required.



Failure to fit an external Check Valve may result in the Sampler continually discharging product from the outlet due to the line pressure exceeding the internal check valve setting.

The external Check Valve will normally be set to 5 barg above the maximum line pressure, ensuring that this is enough to allow for any additional pressure increase created by thermal expansion when any isolating valves are closed and the effects of trace heating and or solar energy. If the cracking pressure is set too low, the valve may open under adverse conditions, causing the Sample Receiver System to overfill and the sample to leak through the relief valve to atmosphere.

The over pressure Relief Valve fitted to the sample line is to provide protection to the Sampler in the event of the sampler being operated against a blocked sample line, e.g. without a sample receiver being fitted or with a full sample receiver. This relief valve should be within the maximum pressure rating of the receiver system but may need to be increased slightly to allow for momentary pressure surges as the sample is being taken.

Ensure that lengths of tubing connecting the sampler to the receiver system are kept to a minimum to minimise "dead" i.e. trapped volume (long lengths of tubing also create extra back pressure and premature seal wear), and that the sample travels downhill at a minimum angle of 15 degrees from the Sampler Outlet to the Receiver to avoid water traps. The sample outlet piping may require heat tracing to prevent blockage.

The Sampler Control System must be capable of supplying a pulse of a minimum 250 milliseconds duration to the Sampler Solenoid Valve to ensure that there is enough time for the Sampler to complete a full stroke at each actuation (in most systems using air 500 milliseconds is normal). The Actuator should dwell momentarily at the bottom of its travel before the Solenoid is de-energised and the Sampler returns to its 'rest' state.

8 Maintenance and Troubleshooting

8.1 Health and Safety Precautions

The Jiskoot™ Hybrid Cell Sampler may be used in applications involving hazardous products.



Care must be taken to avoid contamination by any product trapped within the internal components that may be released as the Sampler is stripped down.

8.2 Weekly maintenance

Regular maintenance is limited to draining excess moisture from the air filter/regulator or on EH applications, checking the level in the hydraulic oil reservoir on the Hydraulic Power Pack.

8.3 Annual maintenance (or as determined by site conditions)

The Jiskoot™ Hybrid Cell Sampler is designed to operate continuously for a period of about 1,000,000 grabs or 12 months before a major overhaul, however this service interval will be affected by the type of product being sampled, particularly the amount of particulate matter such as sand, and therefore cannot be guaranteed. When used in crude oils with high levels of sediment or from mixed carrier shipments, the maintenance interval may be shortened. The service intervals will therefore need to be determined from the experience gained on the application.

The Sampler should be removed from the pipeline and taken to a clean area for servicing.



It is essential that soft vice jaws are used whenever components are required to be held, and that all components, particularly those with sealing faces are thoroughly cleaned of dirt and other contamination by degreasing and drying prior to re-assembly.

A Special Tool Kit is available to assist in fitting some components and seals.

Material No. 3J-45-0127-00 for 1 cc Cell Samplers

Material No. 3J-45-0269-00 for 2 cc Cell Samplers



Failure to use the correct tools may damage seals and other components and will have a direct effect on the future performance of the Sampler.

8.4 Overhaul Instructions

The instructions for strip down and reassembly are applicable to all variations, as the main differences between the standard pneumatically operated Sampler, EH Samplers and HP Samplers are in the Actuator assembly, and/or the Grab size 1 cc or 2 cc.

Upon satisfactory re-assembly, hydraulically actuated (EH) Cell Samplers may be tested using compressed air instead of hydraulic oil where this is more convenient.

Separate details are given for overhaul of individual sub-assemblies and replacement of the Sample Tube Seal. The item numbers in brackets in each section relate to the item numbers of the components shown on the drawing given at the beginning of that section. The item numbers of the components for all the standard versions are identical.

The complete overhaul should be carried out in the following order:

- 1 Removal and overhaul of the Bottom Plug
- 2 Removal and overhaul of the Actuator, Adaptor Ring and Support Tube
- 3 Capture Tube Seals
- 4 Piston and Sample Tube
- 5 Reassembly



It is essential that soft vice jaws are used whenever components are required to be held, and that all components, particularly those with sealing faces are thoroughly cleaned of dirt and other contamination by degreasing and drying prior to re-assembly.

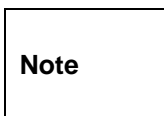

All joints, 'O' Rings and moving parts must be lubricated on assembly using general purpose grease such as Castrol "Spheerol B2" grease or equivalent lithium based water-resistant grease.



Sensia recommend that to prevent seizure, all screwed components are lubricated with Molykote thread lubricant or similar on assembly.

8.5 Torque Settings

The following torque settings should be used in the reassembly of the sampler:

Location	Size	Torque
Support Tube to Actuator Bottom Housing or Support Tube to High Temperature Spacer and High Temperature Spacer to Actuator Bottom Housing	M8	25 Nm/18.4 lbft
Lower Piston Rod to Capture Tube		75 Nm / 55.3 lbft
Catchplate to Piston	M5	10 Nm / 7.4 lbft
Actuator Top to Bottom Housing	M8	25 Nm / 18.4 lbft

8.6 Overhaul

8.6.1 Bottom Plug

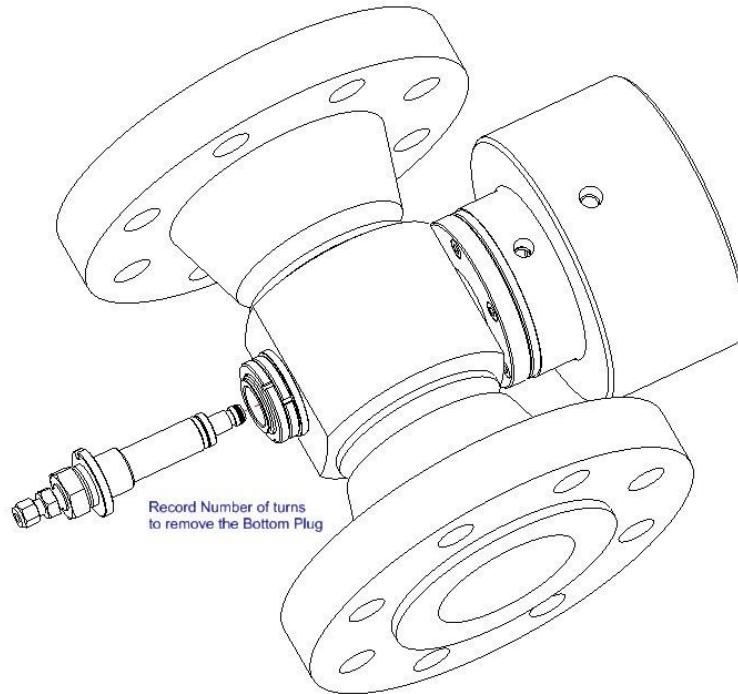

The Bottom Plug incorporates an inline non-return valve, preventing sample returning under low pressure conditions, and the lower process seal.

The Bottom Plug controls the grab volume, this will be factory calibrated. It is strongly recommended removal of the bottom plug is recorded counting the “turns” of the assembly.

Using ‘C’ Spanner, Tool ‘A’, loosen Stop Ring (140) and counting the number of turns, unscrew and remove the Bottom Plug from the bottom of the Main Body.



Write down the number of turns. This MUST be positioned similar on re-assembly to ensure sample volume and that no mechanical damage occurs.

Unscrew and remove the Sample Outlet Connector (490) from the Bottom Plug.

Unscrew and remove the **FIRST** Set Screw (560), **USING AN ALLEN KEY WIND THE SECOND SET SCREW (560) FORWARD TO A STOP, COUNTING AND RECORDING THE NUMBER OF ROTATIONS.** Remove the second Set Screw (560).



This MUST be positioned similar on re-assembly to ensure preload pressure setting.

Remove the Spring (470), Valve Stem (150) and Check Valve Tip (280).

Remove the Seals (440 and 320) and thoroughly clean the grooves.

8.6.2 Actuator

Removal of Sample Tube Head

Remove the Gaiter (480) to expose the Spring (450). Compress the Spring (450) and remove the two parts of the Split Collar (100). Hold the Sample Tube Actuator (70) with a 19 mm (3/4 inch) A/F open-ended spanner, and using a suitable 'C' Spanner, loosen the Sample Tube Head (110). Remove the Sample Tube Head (110).



Removal of Actuator Top

Remove the six M8 screws attaching the Top Actuator Housing.

Remove the top housing complete with Sealing Bush, Locking Ring.

Note

The Lock Ring on top of the Actuator must not be disturbed. If the Bush is moved, the grab size of the Sampler will be altered.

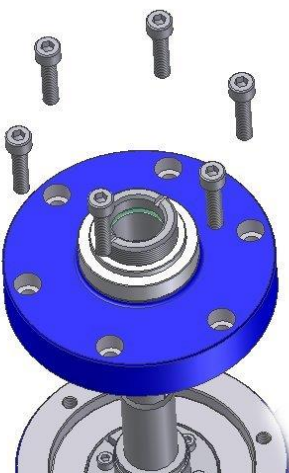

Remove O Rings (410 x 2) and (290).

Removal of Piston and Sample Tube

Remove the complete Piston and Sample Tube assembly



Ensure that the tube surfaces are fully protected until re-assembly.

Removal of Actuator, Adaptor Ring and Support Tube

Loosen and remove the Support Tube Lock Nuts (20) and Spacer Ring (700 and 210) from the Cell Sampler Support Tube.

Note

It is critical that the Support Tube flow through holes and the Actuator ports are aligned as per the original supply. These components should be marked externally prior to disassembly such that they will face in the original direction on reassembly.

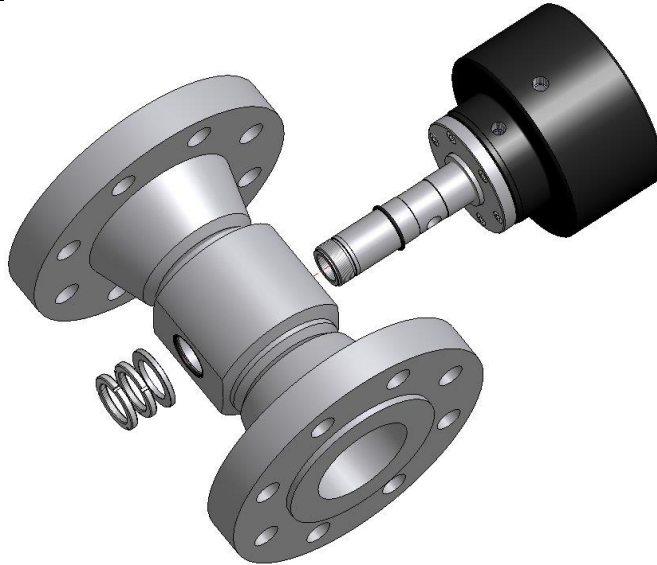

Standard Temperature

Slide the Actuator Sub-Assembly from the unit.

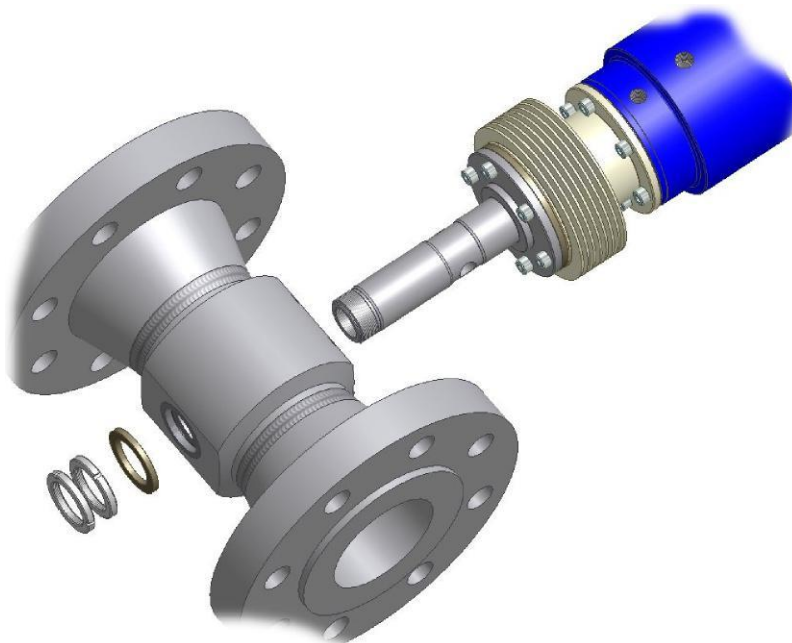

High Temperature

Depending upon the flange size, multiples of Item 210 BP TEMP SPACER and Item 700 BP SPACER will be used. The arrangement must be maintained as supplied.

Remove the Actuator Cap Head Bolts (540) to expose the Capture Tube seals.

8.6.3 Capture Tube Seals

Holding the Support Tube (190) in a protective soft jaw, loosen Lock Ring (250) and remove. The Seal Cartridge (240) complete with the old seals can be removed by hooking a finger through the seals and pulling. If tight, two M4 screws can be fitted and used to aid pulling. Remove the old Slydring (310) and Seals (340), (420) and (430).

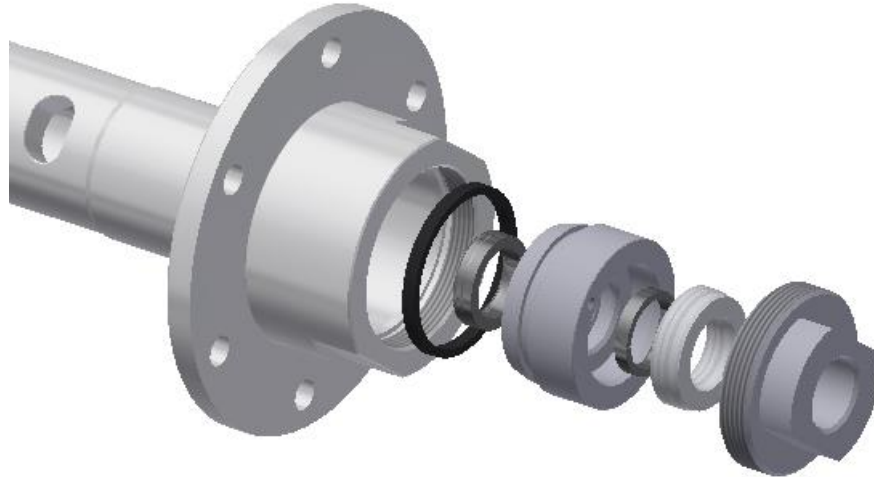

8.6.4 Piston and Sample Tube

Holding the Capture Tube (130) in a protective soft jaw, use a suitable rod of soft material e.g. Delrin; push the bottom end of the Sample Tube (120) approximately 20 mm up inside the Capture Tube (130).



Do NOT push the bottom of the Sample Tube (120) more than 25 mm up inside the Capture Tube (130) as the seal may catch internally and cause damage.

Loosen and remove the six M5 screws releasing the two halves of the Catchplate (80) which may then be removed.

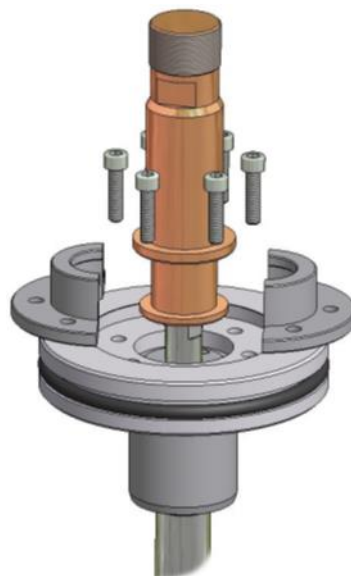

Using a 10 mm open ended spanner locate on the flat sections at the top of the Sample Tube (120) **RED**, then using a 19 mm open ended spanner on the flats of the Sample Tube Actuator (70) **BLUE**, break the joint of the two components. The Sample Tube and Sample Tube Actuator are joined using Loctite 572 thread sealant and this joint will be tight.

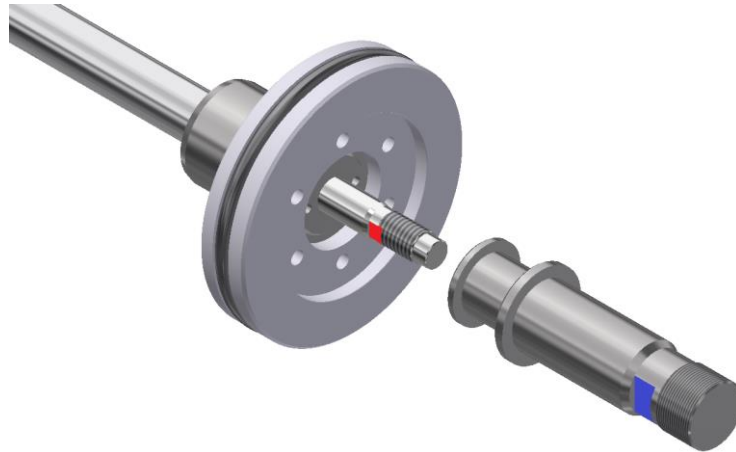

Ensure that the component surfaces are not scratched or marked during maintenance as this will lead to premature seal failure and leakage of process fluids.

Remove the Sample Tube Actuator (70) from the Sample Tube (120) and remove the Piston (60).
Using Nut Peg Spanner, Tool 'E', unscrew and remove the Seal Nut (10) from the Lower Piston Rod and Capture Tube (130).



Remove the Sample tube by pushing the top end of the Sample Tube (120) down and through the seals, the pull out of the Capture Tube (130) from the bottom. Remove and discard the Seal (320) and Sylinder (350).



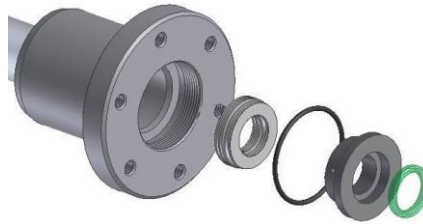

Remove the Quad Ring (270), Seal Ring (370), O ring (370) and Seal (330) from the Lower Piston Rod.

Clean all components using Janitol Plus or similar liquid degreasing agent and a lint free cloth. Examine all tubes and sealing surfaces for wear, scratches and straightness. Any components with damage in the sealing area must be replaced.

Note	The Cell Sampler utilises an integral anti Vacuum valve. We would recommend that a complete Sample Tube assembly be obtained from Sensia should the Sample Tube or Vacuum Valve need replacing.
-------------	--

Note	If the Capture Tube is to be replaced, a complete sub-assembly, including the Lower Piston Rod must be obtained from Sensia.
-------------	---

8.7 Re-Assembly

Assemble as a reversal, all parts being cleaned, inspected and freshly greased to aid assembly. Re-assembly should **ONLY** be conducted by competent trained personnel. Re-assembly should ideally be in a clean environment, with reference to direction of sealing faces and re-alignment of actuator.

Note

All joints, 'O' Rings and moving parts must be lubricated on assembly using general purpose grease such as Castrol "Spheerol B2" grease or equivalent lithium based water-resistant grease.

Note

Sensia recommend that to prevent seizure, all screwed components are lubricated with Molykote thread lubricant or similar on assembly.

8.7.1 Piston and Sample Tube

Warm the new Seal (320) in hot water. Place the Seal (320) over the Seal Loading Mandrel, Special Tool 'G' and push down approximately half the mandrel's length to expand the Seal (320) so it will fit over the Sample Tube (120).

Note

Ensure that the spring is facing the fatter end of the mandrel (Tool 'G') and that you push on the flat face of the seal. Otherwise the seal lips will be damaged and may lead to premature failure.

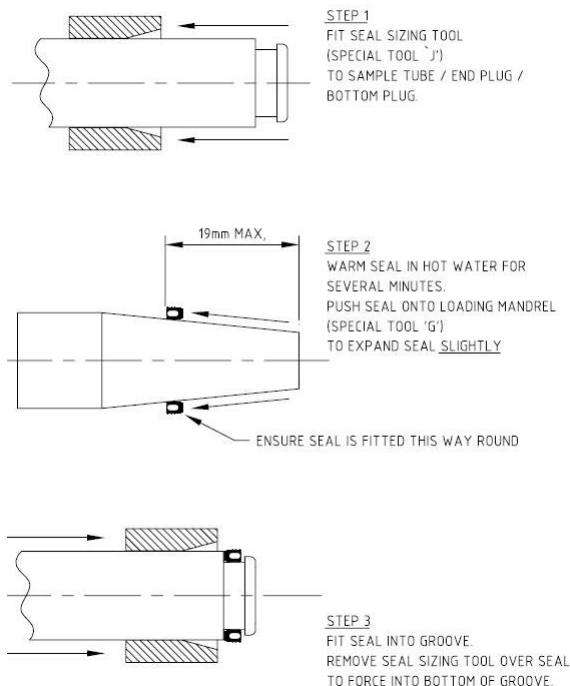

Transfer the Seal (320) from the mandrel and fit to Sample Tube (120) ensuring the Seal (320) is fitted with the seal spring facing towards the Vacuum Breaker (170) end of the Sample Tube (120).

Using fingers, reform the Seal (320) into the groove and then place Seal Assembly Tool, Special Tool 'J' over the Sample Tube (120) (tapered end first) to set the Seal (320) to the required size. Leave for 3-5 minutes. Remove Seal Sizing Tool and check Seal (320) for damage.

Fit the new Slydring (350) by wrapping it round it's groove in the Sample Tube (120) until its diagonal cut ends meet.



Holding the Capture Tube (130) in a protective soft jaw, insert the Sample Tube (120) into the Lower Piston Rod and Capture Tube (130), squeeze the Slydring (350) ends as you push into the Capture Tube (130). Use a suitable rod of soft material e.g. Delrin; push the bottom end of the Sample Tube (120) approximately 20 mm up inside the Capture Tube (130).



Do NOT push the bottom of the Sample Tube (120) such that it extrudes more than 40 mm up from the Lower Piston Rod as the Seal (320) and Slydring (350) may catch internally and will be damaged.

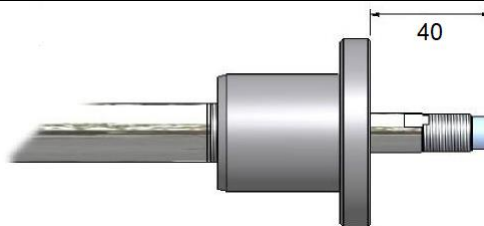

Grease and carefully position the new Seal (330) onto the Sample Tube (120) from the top. Ensure that the Seal (330) is fitted with the seal spring downwards, as indicated.

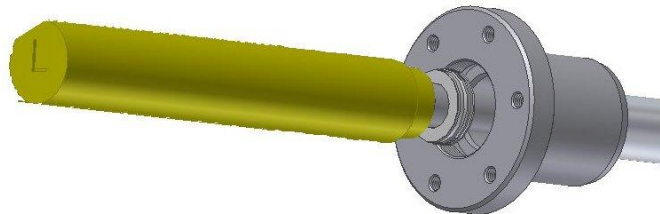

Using Assembly Tool, Special Tool 'L', push the seal into position.

Fit O' Ring (370), Seal Ring (270) and Quad Ring (380) and push into position using Assembly Tool, Special Tool 'L'.

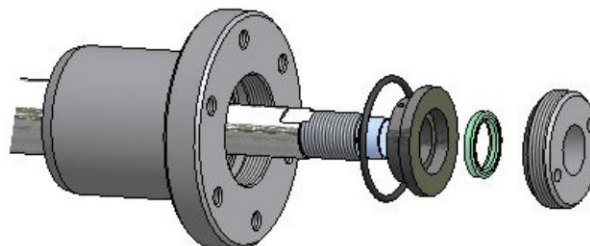

Do NOT use a Hammer to insert Seals as this will damage the seals and lead to failure.

Apply Molykote lubricant to the thread of the Seal Nut (10) and screw into position with the larger chamfered edge facing the seals. Tighten using Nut Peg Spanner - Tool 'E'.

Fit Piston (60) and piston O Ring (300) to the Lower Piston Rod, ensuring the Piston (60) is the correct way around. The deeper cavity of the Piston (60) pushes onto the Lower Piston Rod.

Apply Loctite 572 thread sealant to the Sample Tube (120) thread and screw on the Sample Tube Actuator (70).

Using a 10 mm open ended spanner locate on the flat sections at the top of the Sample Tube (120) **RED**, then using a 19 mm open ended spanner on the flats of the Sample Tube Actuator (70) **BLUE**, tighten these two components.

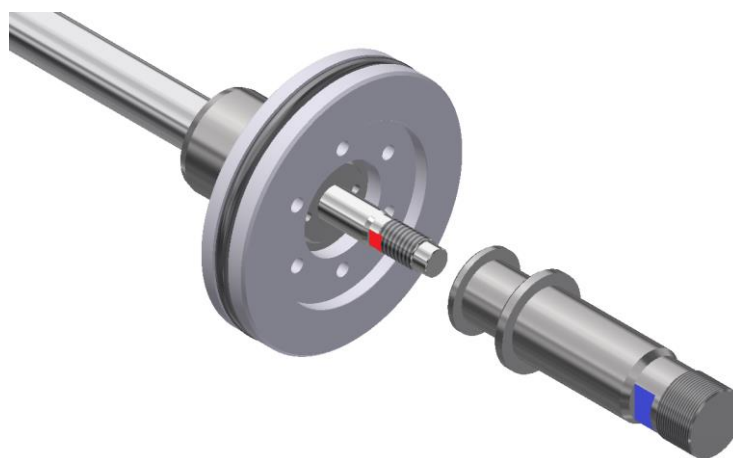

Ensure that the component surfaces are not scratched or marked during maintenance as this will lead to premature seal failure and leakage of process fluids.

Re-fit the two Catchplate (80) to the Lower Piston Rod aligning the piston holes using new cap head screws and Molykote thread lubricant.

EH and Standard Actuator

M5 x 20

High Pressure Actuator

M5 x 25

Torque to 10 Nm / 7.4 lbft.

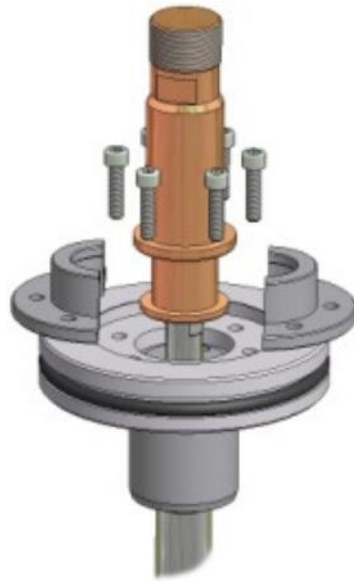

Hydraulic standard pressure Samplers have two O Rings (660) fitted to a smaller Piston (640) and an O Ring (670) sealing the lower edge of a Piston Liner (650) that fits inside the Actuator bore.

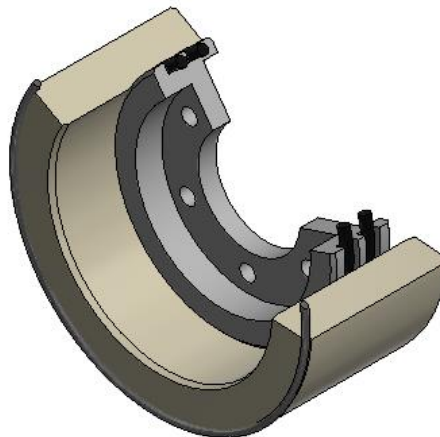

8.7.2 Capture Tube Seal

Holding the Support Tube (190) in a protective soft jaw.

Fit Slydring (310) inside the cleaned Seal Cartridge (240).and then grease and fit Seals (340), (420) and (430) with the seal spring facing the chamfered end of the Seal Cartridge (240)

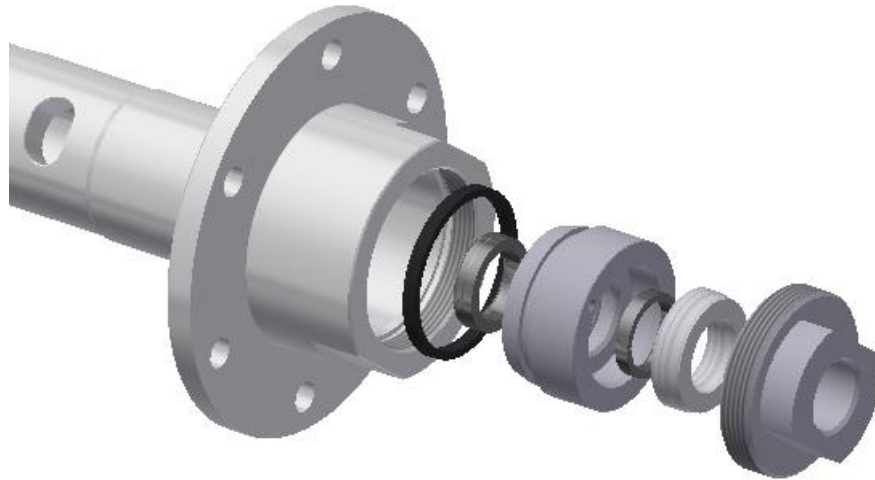

Grease the external of the Seal Cartridge (240) and insert into the top of the Support Tube (190).



Ensure that the Slydring (310) is fully inserted, otherwise this will impede insertion of the Capture Tube (130)

Liberalily grease the internal surface of the Seal Cartridge (240).

8.7.3 Actuator and Support Tube

For Pneumatic applications fit Quad Ring (360) in the centre of the Actuator Housing (40). For Hydraulic applications fit O Ring (680) in the centre of the Actuator Housing (40).

If supplied refit the HT Spacer (200) and the Heat Extension (220).

Lightly grease the bottom face of the Actuator Housing and align to the Support Tube. Apply the Actuator Cap Bolts and Torque 25 Nm / 18.4 lbf.



The Actuator ports must align with the Support Tube flow holes. This orientation should have been noted upon disassembly.

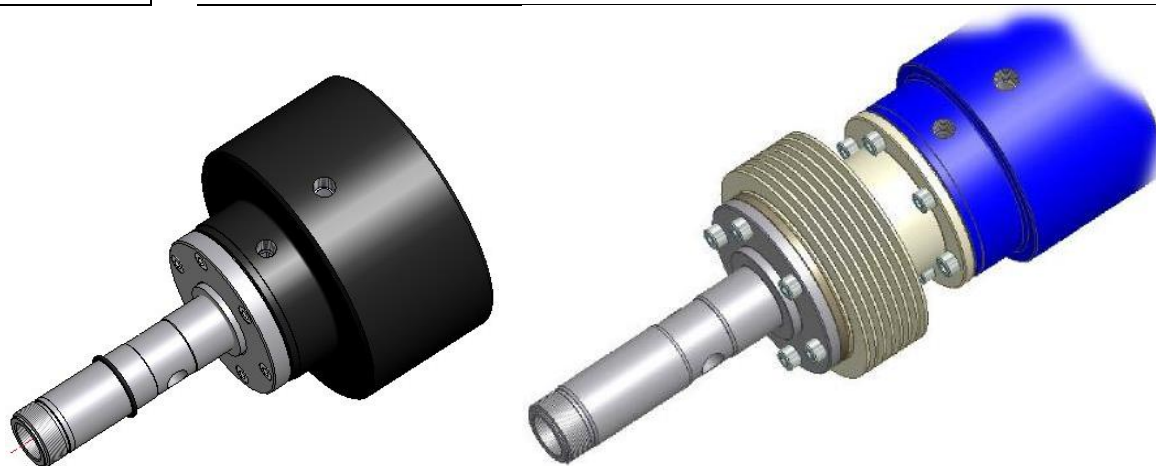

Grease the internal surface of the Actuator Bottom Housing (40) then grease the Capture Tube (130), Lower Piston Rod and the Piston O Ring (300).



Insert the Piston and Tube assembly into the Actuator Housing and Support Tube assembly. There is normal resistance caused by the seals (more noticeable with Hydraulic Piston Liner installed).



Do not use excessive force to insert the Piston and Tubes assembly into the Actuator Housing and Support Tube assembly. Check alignment of the tubes and seals and ensure that the Slydring (310) is fully inserted.

Replace the O Rings (410) in the bore of the Sealing Bush (50) and the O Ring (290) on the Top Housing (30).

Note

The Lock Ring on top of the Actuator must not be disturbed. If the Bush is moved, the grab size of the Sampler will be altered.

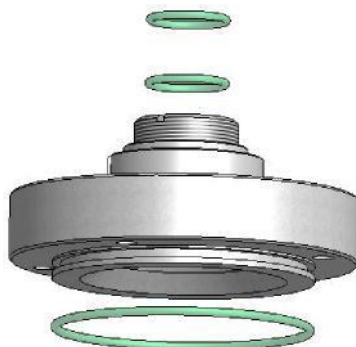

Push the completed Top Housing (30) onto the Actuator Housing (40) ensuring alignment of the Actuator Ports.

Fit 6 off M8 * 35 Cap Head Screws (530) and Torque 25 Nm / 18.4 lbft.

8.7.4 Sample Tube Head

Hold the Sample Tube Actuator with a 19mm (3/4") A/F open-ended spanner, and using a suitable 'C' Spanner, tighten the Sample Tube Head.

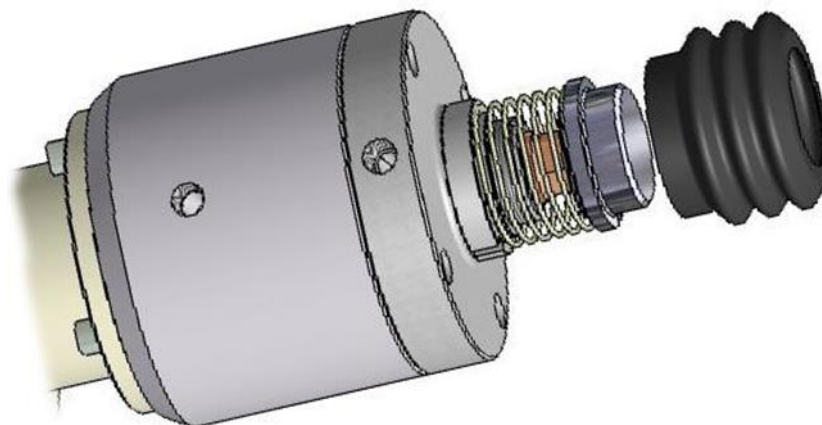

Fit the new Spring (410) and pushing down with the Split Collar (100) insert both halves under the Sample Tube Head (110).

Fit the new Gaiter (480) over the Spring (410) and push down over the Sample Tube Head (110). Secure the Gaiter (480) with a cable tie.

8.7.5 Main Hybrid Cell Body

Note

It is critical that the Support Tube flow through holes and the Actuator ports are aligned as per the original supplied assembly. These components should be marked externally prior to disassembly such that they will face in the original direction on reassembly.

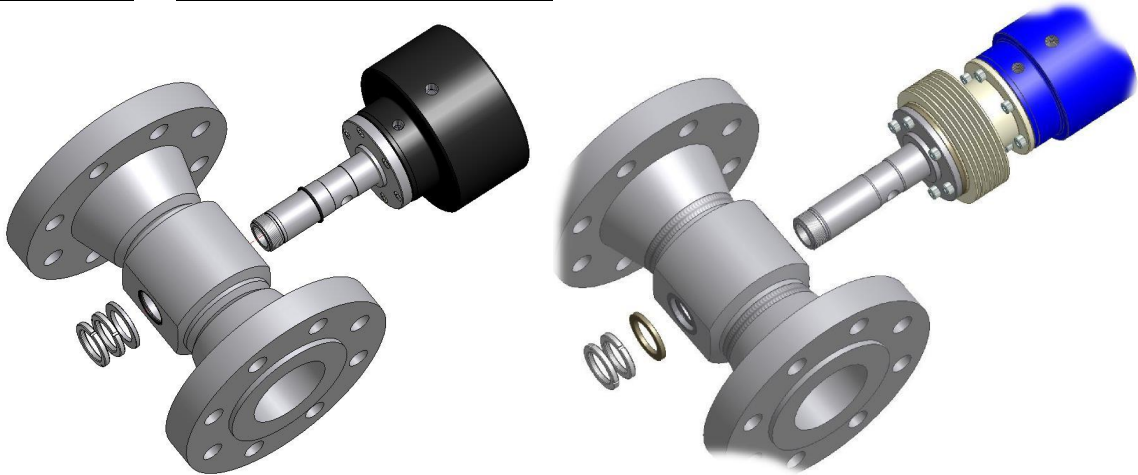

Grease and fit the upper Seal (430) into the seal groove in the top of the flanged Hybrid Cell Sampler body. The spring of the Seal (430) must face the middle of the HCS body.

Liberal grease the Support Tube (190) and slide into the flanged HCS body through the upper Seal (430).



Seal (430) are intricate to install, and great care must be taken to avoid damaging the seal lips.

Hold the Actuator assembly to the flanged HCS body securely to prevent the upper Seal popping out of its groove – some temporary sticky tape will suffice.

Grease and fit the lower Seal (430) into the seal groove in the bottom of the flanged HCS body. The spring of the Seal (430) must face the middle of the HCS body.

Depending upon the flange size, multiples of Item 210 BP TEMP SPACER and Item 700 BP SPACER will be used. The arrangement must be maintained as supplied.

Note

For applications operating at process temperatures below 200 degC C. the two Seals (430) on the HCS body may be replaced by Quad Ring 3J-37-0544-00.

Screw on the Lock Rings (20), Spacer Ring (700) and HT BP Spacer (210) as per the original assembly. Ensure that the flow holes are aligned as per the original supplied assembly.

Note

It is critical that the Support Tube flow through holes and the Actuator ports are aligned as per the original supplied assembly.

Tighten the lock rings with 'C' spanner.

8.7.6 Bottom Plug

Install the Valve Tip (280) to the Check Valve Stem (150), and then insert into the bottom plug. Insert the Spring (470) and screw in the first Set Screw (560), using an Allen Key wind the first Set Screw (560) forward to a Stop, and then loosen the number of rotations counted and noted during dis-assembly. Fit the second Set Screw (560) and tighten to lock in place.

To check the Bottom Plug spring pre-load:

Wind in the first Set Screw until the top of the first Set Screw when measured from the base of the Bottom Plug, should be inserted 16.0 mm.

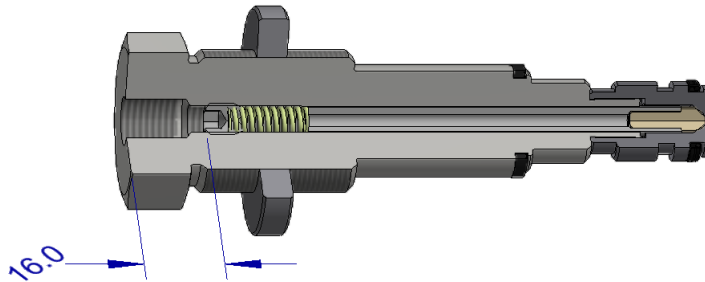

This MUST be positioned similar on re-assembly to ensure preload pressure setting.

Warm the new Seal (320) in hot water. Place the Seal (320) over the Seal Loading Mandrel, Special Tool 'G' and push down approximately half the mandrel's length to expand the Seal (320) so it will fit over the Sample Tube (120).

Note

Ensure that the spring is facing the fatter end of the mandrel (Tool 'G') and that you push on the flat face of the seal. Otherwise the seal lips will be damaged and may lead to premature failure.

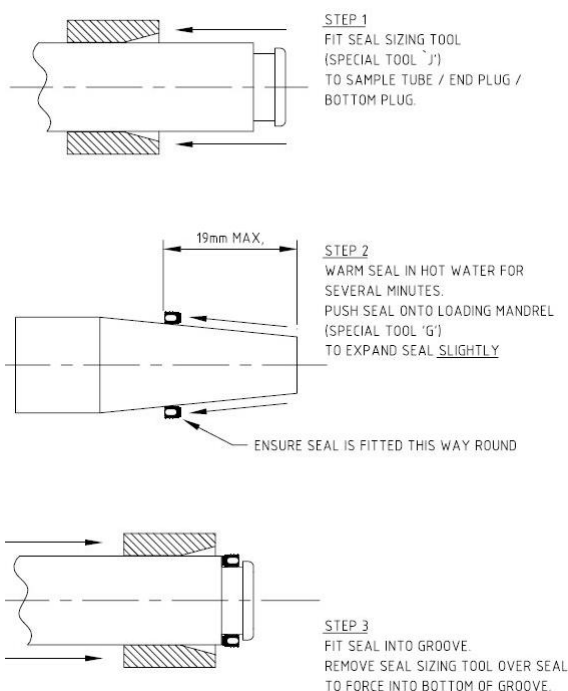

Transfer the Seal (320) from the mandrel and fit to Bottom Plug (230) ensuring the Seal (320) is fitted with the seal spring facing towards the Valve Tip (280) end of the Bottom Plug (230).

Apply the Seal (440) to the Bottom Plug with the spring facing the Valve Tip (280) end of the Bottom Plug (230).

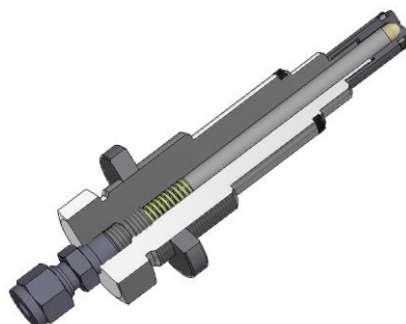

Install the Lock Ring onto the Bottom Plug assembly using Molykote thread lubricant and screw into the HCS body. Counting the number of turns to ensure the insertion is as originally supplied. Tighten the Lock Nut using 'C' Spanner, Tool 'A'.

Install and tighten the Sample Outlet Connector (490).

To check the Bottom Plug insertion and the clearance to the Capture Tube:

With the aid of an assistant apply compressed air to the top port of the Actuator, powering the Actuator downward, simulating a sample grab.

Align and screw in the Bottom Plug Assembly, until it touches the Capture Tube (downward, simulating a sample grab).

Unscrew the Bottom Plug approximately 1/4 turn (0.010").

Tighten the Lock Nut using 'C' Spanner - Tool 'A'.

9 Testing

It is recommended that where a test facility is available, the Sampler is pressure tested and re-calibrated prior to returning to service.

9.1 Witness testing prior to re-installing the Sampler in service.

In the absence of a test facility, the Sampler sealing, and grab integrity may require witness testing after service and prior to re-installation.

Ensure the external back-pressure Check Valve has been serviced in addition to the Sampler and the back-pressure Check Valve is set to correct pressure. (normally set to 5 barg above maximum operating pressure – **NOT** design pressure)



THE SAMPLER IS CAPABLE OF DEVELOPING VERY HIGH SAMPLE DISCHARGE PRESSURES, THIS TEST MUST BE CARRIED OUT WITH GREAT CARE.

The Sampler is capable and operates over a wide range 3.45 to 155.13 barg (50 to 2250 psig). The following procedure is generic for all variations of the 210 Cell Sampler.

A) Bench testing: Blank off one side of the Sampler with a blind flange, charge the Cell Body with suitable fluid (Water or hydraulic oil) and secure second blind flange. Continue to next section.

B) System testing: Ensure the Sampler is depressurised.

9.2 Test equipment



ALL EQUIPMENT INCLUDING INTERCONNECTING PIPEWORK OR FLEXIBLE HOSE SHOULD BE INSPECTED AND VALIDATED FOR THE REQUIRED TEST PRESSURE.

Assemble a “test rig” (as below sketch), comprising a “Tee” fitting, with the correctly rated Back-Pressure Check Valve and Needle Control Vent Valve. Connect the “test rig” to the Sample Outlet Port of the Sampler and drain to suitable receptacle.

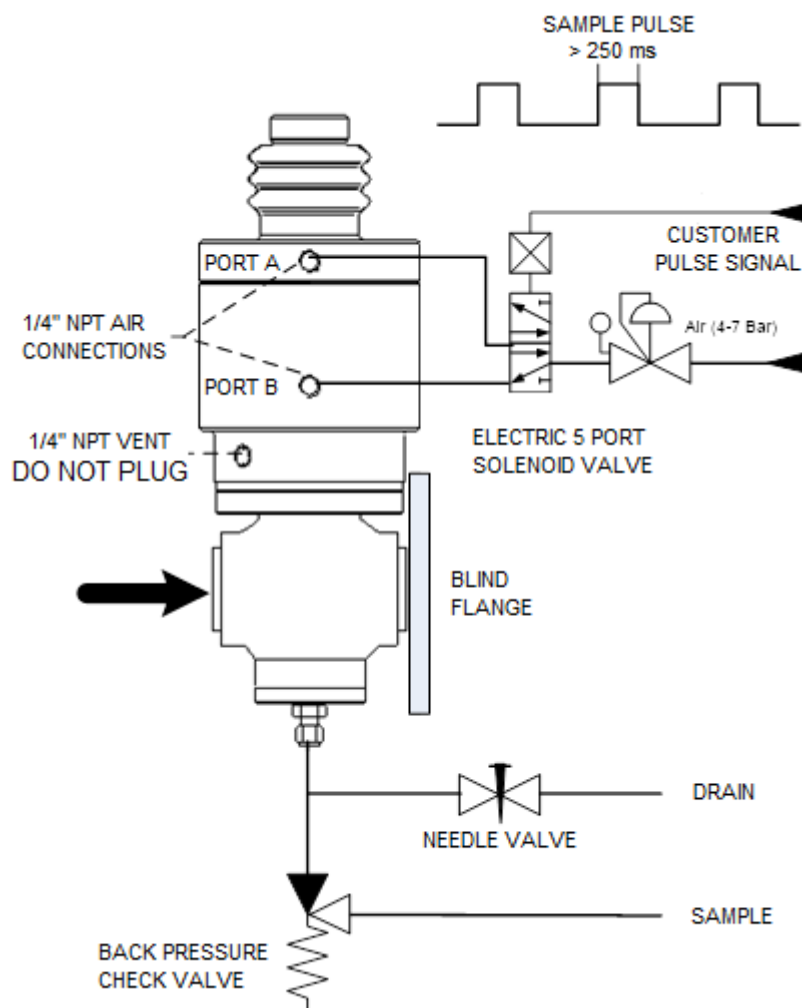

Figure 11 - Test Configuration

Ensure the back-pressure Check Valve is rated to correct system pressure and the outlet is connected to a suitable receptacle. It is strongly recommended that the external back-pressure Check Valve be replaced at the time of Sampler Overhaul. Please reference originally supplied tag plate details when requesting quotation.

Note the pneumatic or hydraulic actuator pressure setting is correct at 5 to 8 barg

Operate the Sampler in single grab sequence until the sample grab is forced through the back-pressure Check Valve. This will validate the process grab is operating and sealing correctly.

The external back-pressure Check Valve prevents oil seepage under operating conditions.

Upon satisfactory testing, isolate the Sampler and open the Needle Control Valve, relieving the pressure on the "test rig".

10 Frequently Asked Questions



Prior to undertaking any of the following checks, ensure the Sampler outlet is un-obstructed and connected to a suitable receptacle.

10.1 Sampler Does Not Operate

Check that all Actuator and electrical connections are secure and correct

Check that the Actuator pressure, indicated on the air regulator or Hydraulic Power Pack discharge pressure gauge is between 5 to 8 barg, re-adjust as required. For Hydraulic actuation the pressure may need to be set as high as 10 barg depending upon connecting hose length and diameter, and the process operating pressure.

Check Sampler Controller is demanding a grab and that any interposing relays are operating satisfactorily.

Is solenoid being energised? - Check Solenoid Fuse and operate manually where solenoid has manual override facility. Ensure that the electrical pulse signal to energise the Solenoid Valve is the correct duration (500 milliseconds minimum for air, 1 second minimum for hydraulic applications). Longer pulse duration will be required when operating at high process pressures.

If the Sample Tube Head moves slightly, the sample outlet may possibly be obstructed. Check that external Check Valve setting and ensure the line to the Sample Receiver is not blocked.

Incorrect re-assembly?

10.2 Sampler Operates but Does Not Produce A Sample

Check all valves are open and that there is fluid in the pipeline.

Ensure the Actuator pressure is correct. If the pressure is too low, the Actuator will not stroke fully. Check the stroke of the Actuator is correct - the Sample Tube Head should move approximately 19mm.

Degradation of the Process Grab Seals, Vacuum Breaker, or the Internal non-return valve will cause a reduction or loss of sample grab volume.

10.3 Sampler fails to take adequate sample

Check that the Actuator pressure, indicated on the air regulator or Hydraulic Power Pack discharge pressure gauge is between 5-8 Barg, re-adjust as required.

Check Sample Receiver is not full, or the sample outlet piping blocked through waxing.

Check the external Check Valve fitted to Sampler Outlet Adapter is set to 5 Bar above line pressure for normal low-pressure receiver systems and to 1 Bar where high-pressure sample receivers are being used.

Check the external check valve is set with the correctly sized spring for the system usage.

Check that the external relief valve fitted to the sample discharge lines is not passing.

Ensure that the Sampler Controller is not either demanding too fast a sample grab rate (120 grabs per minute maximum), or that the signal to the solenoid is too short and not allowing the Actuator to travel to the full extent of its stroke.

If the above are satisfactory, then the Sampler will require a change of internal seals.

10.4 Sampler takes excessive sample

Check the External Check/Relief Valve fitted to Sampler Outlet Adapter is set to 5 barg above line pressure and is not passing fluid when the Sampler is not in operation.

If the above are satisfactory, then the Sampler will require a change of internal seals.

10.5 Process Fluid Leaks

The Jiskoot™ Cell Sampler contains serviceable components and seals and are dependable upon site conditions for service intervals.

The Sampler should be fully serviced upon noticeable process weep.

10.6 Vibration

Vibration is most likely to occur external to the sampler.

11 Recommended Spares List

When requesting assistance or spare parts, please advise the Sampler Model and Serial Numbers to ensure that the correct options are supplied.

11.1 Special Tool Kits

Material No. 3J-45-0127-00 for 1 cc Cell Samplers

Material No. 3J-45-0269-00 for 2 cc Cell Samplers

11.2 Ancillary Equipment

Part/Sub- Assembly	Commissioning	1 Year Operation	2 Year Operation
Solenoid Coil (to suit application)	-	1	1

12 Product Specific Drawings

Series 210 Hybrid Cell Sampler 2"	32031
Series 210 Hybrid Cell Sampler 3"	32032
Series 210 Hybrid Cell Sampler 4"	32033
210 Hybrid Cell Sampler Assembly Drawing	33740

13 Addenda

13.1 2cc Cell Sampler

The principle of operation of the 2cc version is identical to the standard Hybrid Cell Sampler and achieves the increased sample size using larger diameter Capture and Sample area.

Overhaul of the Sampler is the same to the standard unit, except for process Seal size and tooling mandrel.

13.2 Addenda – Grab Volume Adjustment

Variations include Seal material, assembly and setup for grab volume remains similar for all EH, HP and standard variations.

- a) Molykote 1000 grease all threads.
- b) Align Actuator Bush with the longer thread facing the Adjuster Lock Nut.
- c) Screw the Adjuster Lock Nut to the Actuator Bush.

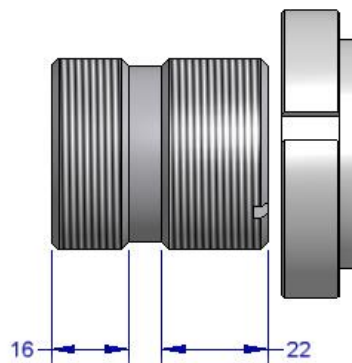

Volume Grab pre-adjustment

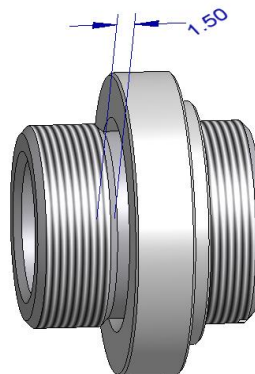

1cc install the Actuator Bush “O” Ring and position the lock nut approximately 1.5mm back from the undercut.

2cc install the Actuator Bush “O” ring and position the lock nut in line with the start of the 16mm thread.

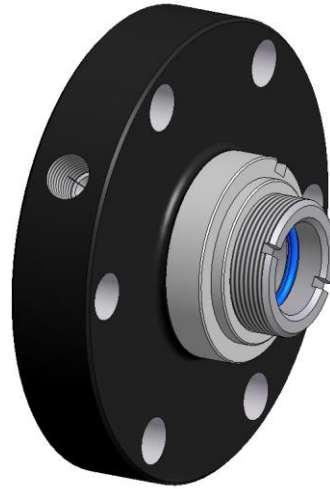

Screw the assembly into the Top Housing and tighten.
Install the two seals within the Actuator Bush.
Install the "O" ring within the Top Housing.

14 Disclaimer

WARRANTY - LIMITATION OF LIABILITY: Seller warrants only title to the products, software, supplies and materials and that, except as to software, the same are free from defects in workmanship and materials for a period of one (1) year from the date of delivery. Seller does not warrant that software is free from error or that software will run in an uninterrupted fashion. Seller provides all software "as is". THERE ARE NO WARRANTIES, EXPRESS OR IMPLIED, OF MERCHANTABILITY, FITNESS OR OTHERWISE WHICH EXTEND BEYOND THOSE STATED IN THE IMMEDIATELY PRECEDING SENTENCE. Seller's liability and Buyer's exclusive remedy in any case of action (whether in contract, tort, breach of warranty or otherwise) arising out of the sale or use of any products, software, supplies, or materials is expressly limited to the replacement of such products, software, supplies, or materials on their return to Seller or, at Seller's option, to the allowance to the customer of credit for the cost of such items. In no event shall Seller be liable for special, incidental, indirect, punitive or consequential damages. Seller does not warrant in any way products, software, supplies and materials not manufactured by Seller, and such will be sold only with the warranties that are given by the manufacturer thereof. Seller will pass only through to its purchaser of such items the warranty granted to it by the manufacturer.

